

MIC3 – IGNITION CONTROLLER

OPERATING MANUAL



MIC3
MOTORTECH IGNITION CONTROLLER

Copyright

© Copyright 2014 MOTORTECH GmbH. All rights reserved.

Distribution and reproduction of this publication or parts thereof, regardless of the specific purpose and form, are not permissible without express written approval by MOTORTECH. Information contained in this publication may be changed without prior notice.

Trademarks

All trademarks and logos displayed or used in this publication are the property of the respective entitled person.

TABLE OF CONTENTS

1 General Information	7
1.1 What Is the Purpose of this Operating Manual?	7
1.2 Who Is this Operating Manual Targeted to?	7
1.3 Which Symbols Are Used in the Operating Manual?	7
1.4 Which Abbreviations/Acronyms Are Used in the Operating Manual?	8
2 Safety Instructions	10
2.1 General Safety Instructions	10
2.2 Electrostatic Discharge Hazards	11
2.3 Special Safety Instructions for the Device	11
2.4 Proper Disposal.....	12
3 Intended Use	13
3.1 Functional Description	13
3.2 Applications.....	13
4 Product Description	14
4.1 Technical Data	14
4.1.1 Certifications	14
4.1.2 Mechanical Data	14
4.1.3 Warning Notices on the Device.....	14
4.1.4 Product Identification – Labeling on the Device	14
4.1.5 Electrical Data.....	15
4.1.6 Interfaces	17
4.1.7 Requirements for External Equipment.....	18
4.1.8 Overview Drawings	19
5 Installation Instructions	21
5.1 Unpacking.....	21
5.2 Installation of the Ignition Controller	21
5.3 Determine the Installation Location of the Pickup	22
6 Wiring of the Device	23
6.1 Input and Output Wiring on the Controller	23
6.1.1 Input cabling.....	23
6.1.2 Input Wiring – Power Supply.....	25
6.1.3 Input Wiring – Pickups	26
6.1.4 Input wiring – Ignition timing and safety devices	28
6.1.5 Output Wiring – Digital Outputs (Go/NoGo, GPO, ASO)	29
6.1.6 Output Wiring – PowerView3	31

TABLE OF CONTENTS

6.1.7 Output Wiring – CAN Bus – Interface	32
6.1.8 Output Wiring – RS485 Interface.....	33
6.2 Ignition Coil Wiring.....	34
6.3 Straight Order Wiring of the Ignition Outputs	36
7 Functions	39
7.1 Pickup Sensitivity	39
7.2 Monitoring of Pickup Signals.....	39
7.3 Go/NoGo.....	39
7.4 Timing Correction	40
7.4.1 Analog Inputs	41
7.4.2 Cylinder-to-Cylinder Alignment.....	43
7.4.3 Speed Curve.....	43
7.4.4 Timing Correction	43
7.5 Firing angle	43
7.6 HV-Power Supply Error Monitoring.....	43
7.7 Schedules A/B.....	44
7.8 Alarms.....	44
7.9 GPO: General Purpose Output	45
7.10 ASO: Auxiliary Synchronization Output.....	45
7.11 Ignition Energy.....	47
7.12 Access Control.....	47
8 Settings via the MICT	49
8.1 MICT System Requirements	49
8.2 MICT Installation	49
8.3 Access Levels in the MICT	50
8.4 Configuration Pages (Overview)	51
8.5 Menu Bar and Toolbar.....	52
8.6 Online Update Settings	55
8.7 Self Test	56
8.8 Pickup -Trace	57
8.9 Access Control for the MIC ₃	59
8.9.1 Enabling/Disabling Access Control	60
8.9.2 Login/Logout	60
8.9.3 Changing the PIN	60
8.9.4 Resetting all PINs	61
8.10 Working with Configurations	61
8.10.1 Create, Open, Save.....	62

8.10.2	Upload, Download	63
8.10.3	Compatibility Information	63
8.11	Configuration	64
8.11.1	Engine – Parameters	64
8.11.2	Engine – Cylinder Names	67
8.11.3	Engine – Ignition Outputs	68
8.11.4	Engine – Ignition Coils	70
8.11.5	Engine – Pickups	72
8.11.6	Timing – Analog Inputs	76
8.11.7	Timing – Schedule A/B – General	78
8.11.8	Timing – Schedule A/B – Energy	80
8.11.9	Timing – Miscellaneous	81
8.11.10	Inputs/Outputs – Alarms	82
8.11.11	Inputs/Outputs – ASO1 (auxiliary synchronization output)	84
8.11.12	Inputs/Outputs – Inputs	85
8.11.13	Miscellaneous – Communication	86
8.11.14	Miscellaneous – Information	88
8.12	Runtime Data	89
8.12.1	Runtime Data – Overview	90
8.12.2	Runtime Data – Timing	93
8.12.3	Runtime Data – Ignition	94
8.12.4	Runtime Data – Bank A	96
8.12.5	Runtime Data – States	98
8.12.6	Runtime Data – Message Log	101
8.12.7	Runtime Data – Diagnostics	106
8.12.8	Runtime Data – Temperatures	108
8.12.9	Runtime Data – Information	110
8.13	Log	111
8.14	Runtime Adjustments	112
8.14.1	Runtime Adjustments – Reset	113
8.14.2	Runtime Adjustments – Timing	114
8.14.3	Runtime Adjustments – Energy	115
8.14.4	Runtime Adjustments – Secondary Voltage Estimation Calibration	117
8.14.5	Runtime Adjustments – Secondary Short Calibration	118
8.15	Cylinder Individual Offsets	119
8.16	Schedule Curve	120
8.16.1	Schedule Curve – Simulation	121
8.16.2	Schedule Curve – Runtime Values	122
8.17	Coils	123

TABLE OF CONTENTS

8.17.1 General.....	124
8.17.2 Minimum Energy Limitation Curve	126
9 Operation	127
9.1 Start-up	127
9.2 Shut-Down.....	127
9.3 Firmware Update	127
10 Disturbances.....	131
10.1 Possible Faults.....	131
10.2 Causes for Faults	131
10.2.1 Overspeed	131
10.2.2 Output Error Detection	131
10.2.3 Misfire Detection (Primary)	131
10.2.4 Pickup Input Errors.....	132
10.2.5 Acknowledging Faults	132
10.3 Troubleshooting and Eliminating Errors.....	132
10.3.1 Running a Self Test.....	132
10.3.2 Causes of Typical Errors	133
10.3.3 Customer Service Information	135
10.3.4 Returning Equipment for Repair / Inspection.....	135
10.3.5 Instructions for Packaging the Equipment.....	135
11 Maintenance.....	136
11.1 Maintenance Instructions.....	136
11.2 Spare Parts and Accessories	136
12 Index	137

1 GENERAL INFORMATION

Read through this operating manual carefully before use and become familiar with the machine. Installation and start-up should not be carried out before reading and understanding this document. Keep this manual readily available so that you can reference it as needed.

1.1 What Is the Purpose of this Operating Manual?

This manual serves as an aid for the installation and operation of the product and supports the technical staff with all operating and maintenance tasks to be performed. Furthermore, this manual is aimed at preventing dangers to life and health of the user and third parties.

1.2 Who Is this Operating Manual Targeted to?

The operating manual provides a code of conduct for personnel tasked with the set-up, operation, maintenance, and repair of gas engines. A certain level of technical knowledge with respect to the operation of gas engines and basic knowledge of electronic ignition systems are necessary. Persons who are only authorized to operate the gas engine shall be trained by the operating company and shall be expressly instructed concerning potential hazards.

1.3 Which Symbols Are Used in the Operating Manual?

The following symbols are used in this manual and must be observed:



Example

This symbol indicates examples, which point out necessary handling steps and techniques. In addition, you receive additional information from the examples, which will increase your knowledge.



Notice

This symbol indicates important notices for the user. Follow these. In addition, this symbol is used for overviews that give you a summary of the necessary work steps.



Warning

This symbol indicates warnings for possible risks of property damage or risks to health. Read these warning notices carefully and take the mentioned precautionary measures.

1 GENERAL INFORMATION



Danger

This symbol indicates warnings for danger to life, especially due to high voltage. Read these warning notices carefully and take the mentioned precautionary measures.

1.4 Which Abbreviations/Acronyms Are Used in the Operating Manual?

In the manual or the user interface, the following abbreviations / acronyms are used.

Abb.	Term	Description	Explanation
ADV	Advance	Advanced with respect to top dead center	Indicates the direction for timing
ASC	Automatic Spark Control		Automatic spark control
ASO	Auxiliary Synchronization Output		Output for synchronizing the MIC ₃ and other controllers
CAN Bus	Controller Area Network Bus	Bus for control devices / networks	Asynchronous serial connection system for linking control units
CE	Conformité Européenne	Conformity with EU directives	Mark based on EU legislation for certain products in conjunction with product safety
CPU	Central Processing Unit	Central processing unit	
CSA	Canadian Standards Association		Organization that defines standards, inspects products for safety compliance, and issues pertinent certifications.
DC	Direct Current	Direct Current	
DetCon	Detonation Control System	Detonation control system	Serves to prevent major engine damage that can be caused by knocking combustion.
EMI	Electromagnetic Interference	Electromagnetic interference	
EMC	Electromagnetic Compatibility		Compatibility of electrical or electronic equipment items with their surroundings

Abb.	Term	Description	Explanation
GPI	General purpose input	Multi-purpose input	
GPO	General Purpose Output	General Purpose Output	
HV	High voltage	High voltage	
°crankshaft	Crankshaft angle in degrees		Unit for the rotation angle of the crankshaft
LED	Light Emitting Diode	Light emitting diode	Light emitting electronic semiconductor
MIC	MOTORTECH Ignition Controller	MOTORTECH ignition controller	
MICT	MOTORTECH Integrated Configuration Tool		Software for MIC ₃ configuration
ATDC	After top dead center		
TDC	Top dead center		
POT	Potentiometer		Continuously adjustable potential divider
PWR	Power	Output / current	
RET	Retard	Retarded with respect to the top dead center	Indicates the direction for timing
USB	Universal Serial Bus		Serial connection system to link a computer to external devices
BTDC	Before top dead center		

2 SAFETY INSTRUCTIONS

2.1 General Safety Instructions

The following safety instructions must be followed in the area in which the device is operated:



High voltage! Danger to life!

While the engine is running, the area around the ignition system especially holds the risk of danger due to high voltage. The following parts should therefore not be touched or removed unless explicitly stated otherwise:

- Ignition coils and caps
- Wires of the high voltage circuit
- In- and output wiring of the ignition controller
- Pickups and their wiring



Danger to persons with pacemakers!

Electromagnetic impulses in the wiring of the ignition system may exceed the permissible limits of pacemakers. Persons with pacemakers must therefore not be present in the vicinity of the ignition system being operated. Mark the operating location of the ignition system with the corresponding standardized warning symbol.

MOTORTECH equipment is manufactured as state of the art and therefore safe and reliable to operate. Nevertheless the equipment can cause risks or damages can occur, if the following instructions are not complied with:

- The gas engine must only be operated by trained and authorized personnel.
- Operate the equipment only within the parameters specified in the technical data.
- Use the equipment correctly and for its intended use only.
- Never apply force.
- For all work, such as installation, conversion, adaptation, maintenance, and repair, all equipment must be disconnected from the power supply and secured against unintentional restarting.
- Perform only such maintenance and repair work as is described in this operating manual, and follow the instructions given while working. For maintenance of the equipment, only use spare parts supplied by MOTORTECH. Further work must only be performed by personnel authorized by MOTORTECH. Non-compliance with the instructions will void any warranties for the proper function of the equipment as well as the responsibility for the validity of the certifications.
- Safety devices must not be dismantled or disabled.
- Avoid all activities that can impair the function of the equipment.

- Operate the equipment only while it is in proper condition.
- Investigate all changes detected while operating the gas engine or ignition system.
- Ensure compliance with all laws, directives and regulations applicable to the operation of your system, including such not expressly stated herein.
- If the system is not entirely tight and sealed, gas may escape and lead to an explosion hazard. Upon completion of all assembly works, always check the system's tightness.
- Always ensure adequate ventilation of the engine compartment.
- Ensure a safe position at the gas engine.

2.2 Electrostatic Discharge Hazards

Electronic equipment is sensitive to static electricity. To protect these components from damage caused by static electricity, special precautions must be taken to minimize or prevent electrostatic discharge.

Observe these safety precautions while you work with the equipment or in its vicinity.

- Before performing maintenance or repair work, ensure that the static electricity inherent to your body is discharged.
- Do not wear clothing made from synthetic materials to prevent static electricity from building up. Your clothing should therefore be made of cotton or cotton mix materials.
- Keep plastics such as vinyl and Styrofoam materials as far away from the control system, the modules, and the work environment as possible.
- Do not remove the circuit boards from the housing of the device.

2.3 Special Safety Instructions for the Device



Explosion hazard!

When the system is powered up, do not remove any connectors unless the system is not located in a potentially explosive atmosphere.



Explosion hazard!

The replacement of parts or assemblies can impair compliance with CSA Class I, Division 2 (Group C, D), T4.

2 SAFETY INSTRUCTIONS



Explosion hazard!

Never remove the equipment while the device is connected to a power source unless the system is not located in an explosive environment.



Explosion hazard!

Do not remove or replace the fuse while the equipment is live.



Risk of burning!

The surfaces of the system may heat up to high temperatures.



Operational safety!

All connector screws and screw joints must be adequately tightened.



Risk of damage!

Magnetic fields and heat occur when welding, which may damage or destroy the MIC₃. Therefore, pay attention to the following when welding:

- Disconnect all electrical connections to the MIC₃ prior to welding.
- Protect the MIC₃ against direct contact with the welding unit and magnetic fields, sparks and liquid metal.

2.4 Proper Disposal

After the expiration of its service life, MOTORTECH equipment can be disposed of with other commercial waste, or it may be returned to MOTORTECH. We will ensure its environmentally friendly disposal.

3 INTENDED USE

3.1 Functional Description

The devices of the MIC3 series are microprocessor controlled ignition systems, that are comprised of one 32 bit main processor (CPU) and an output board.

Please note that the manufacturer is not required to implement configurations of the ignition controller for specific engines, and that devices may be delivered without pertinent configuration.

The ignition controllers of the MIC3 series use information supplied by the pickups to precisely determine the correct timing for the respective outputs. The ignition timing is influenced by various inputs. This can be implemented using analog input signals, a speed characteristic, or using a serial interface (USB, CAN bus, RS485).

During operation, the ignition controllers continuously monitor the system status of all installed pickups and the correct operation of the primary ignition circuit by checking the information received.

Depending on the severity of an error that is detected, the device will shut down immediately or warn the operator. A corresponding message can be viewed on a connected PC.

To protect the engine, the ignition controllers additionally have an adjustable overspeed shut-off.

3.2 Applications

The ignition controllers of the MIC3 series are designed for specific 2- or 4-stroke gas engines. From 1 to max. 12 ignition outputs are available.

The ignition controllers supply the energy required for the corresponding ignition coils of the gas engines and can supply signals for peripheral equipment.

Any use other than the one described in the operating manual shall be considered improper use and will result in the voiding of all warranties.

4 PRODUCT DESCRIPTION

4.1 Technical Data

4.1.1 Certifications

Certification pursuant to CSA is planned.

4.1.2 Mechanical Data

The MIC₃ has the following mechanical characteristics.

Feature	Value
Dimensions	250 mm x 240 mm x 89.5 mm (9.84 " x 9.45 " x 3.52 ") (length x width x height)
Weight	3.1 kg (6.8 lbs)
Shape of device	See chapter <i>Overview Drawings</i> on page 19.
Mechanical environmental conditions	The housing is resistant to general atmospheric contaminations. Resistant to gas engine lubricants. Protection class: 1 Protection: IP54 The specified protection class and type is only guaranteed if the protective cap is firmly attached to the USB connection.
Climatic environmental conditions	Housing surface temperature: -40 °C to +65 °C (-40 °F to +149 °F)

4.1.3 Warning Notices on the Device

WARNING! Read and understand the installation and operating manual prior to installing or making any adjustments.

EXPLOSION HAZARD! Do not disconnect while circuit is live unless area is known to be non-hazardous. For wiring details please refer to operating manual.

CAUTION! Do not pressure wash this ignition module. Damage to electronic components may result.

4.1.4 Product Identification – Labeling on the Device

The necessary numbers for unique product identification are on the device:

- Product number of the ignition controller (P/N)

- Arrangement number of the ignition controller (A/N)
- Serial number of the ignition controller (S/N)



www.motortech.de



P/N	66.00.310-12
A/N	321.12.C0Q0-000-AA-0
S/N	012345678

4.1.5 Electrical Data

The MIC₃ has the following electrical characteristics.

Feature	Value
Power consumption	max. 65 W with 24 V
Power supply	10 to 32 V DC
Required current	Current max. 6.0 A. An estimation of the power requirements can be found in the table below.
Number of outputs	6 or 12 outputs
Firing angle	The size of the firing angle depends on the max. overspeed. The smallest ignition angle can be calculated using the following formula: $\text{Ignition Angle} = \frac{\text{Overspeed} [\text{min}^{-1}]}{60} \times 360^\circ \times 2,8 \text{ ms}$
Ignition frequency	With full energy output (all 12 ignition outputs with 200 mJ), an ignition frequency of 180 Hz as continuous load is possible. In the event of less ignition energy or in case of a brief overload, 200 Hz is possible. The maximum output load of 40 W must not be exceeded. $\text{Ignition Frequency}_{2 \text{ Stroke}} = \frac{\text{Overspeed} [\text{min}^{-1}]}{60} \times \text{Number of Ignition Outputs}$ $\text{Ignition Frequency}_{4 \text{ Stroke}} = \frac{1}{2} \times \frac{\text{Overspeed} [\text{min}^{-1}]}{60} \times \text{Number of Ignition Outputs}$
Output connector	17-pin military connector

4 PRODUCT DESCRIPTION

Estimation of Current Requirements

These current values are based on a nominal speed of 1800 rpm and 200 mJ energy.

Outputs	Voltage	Required current	Voltage	Required current
8	24 V	2.3 A	12 V	4.0 A
12	24 V	3.3 A	12 V	5.0 A

Electrical Data for Inputs and Outputs

The inputs and outputs of the ignition controller have the following electrical data:

Inputs and outputs	Values
Analog current input	Working resistance 27 Ω , damping 1 μ F
Analog voltage input	Working resistance 12.4 Ω , damping 200 nF
Aux. Analog Input Supply Voltage	5 to 24 V / 50 mA depending on the configuration in the MICT
Digital Input (Start/Stop)	Wiring Input current: max. 20 mA Ignition stop: 0 to 0.8 V Ignition release: 2.8 to 32 V
Digital Input (schedule A/B)	Wiring Input current: max. 20 mA Schedule A: 0 to 0.8 V Schedule B: 2.8 to 32 V
Go/NoGo and GPO Outputs	One GPO (General Purpose Output) and one Go/NoGo output Implementation as optical MosFET Voltage applied: 7 to 32 V DC max. Peak/steady current: 100 mA DC max. Output: 2.5 W max. Internal resistance: 58 to 60 Ω Activation delay: 0.5 ms / 100 mA load max. Deactivation delay: 0.2 ms / 100 mA load max. If a short is found at the output, a safety circuit, which makes the output highly resistive, is found at the output, so that the current sets itself at 50 to 60 mA.
LED	Six LEDs are used as status indicators.

Inputs and outputs	Values
ASO Output	TTL level (5 V) max. current: ± 10 mA
Pickup Input	Impedance: 10 kΩ Voltage supply for inductive pickup can be set using the MICT at 5 to 24 V. Max. frequency for the pickups: 10 kHz The formula for determining the frequency of the pickups can be found in the note following this table. For a pickup output impedance of 120 Ω to 10 kΩ, the pickups connected to the MIC ₃ may not have a higher voltage than ±40 V peak-peak and the connected power may not exceed 1 Watt.
Ignition Coil Outputs	Output voltage: 250 V max. Output energy in normal operation mode: 200 mJ max. Output energy in the start phase: 300 mJ max.



Frequency of the pickups

The frequency of the pickup is calculated as per the following formula.

$$Frequency = \frac{Overspeed [min^{-1}]}{60} \times Number\ of\ Pickup\ Event\ per\ Revolution$$

4.1.6 Interfaces

Depending on the device variant, the following interfaces are available:

USB Interface

- Compatible with USB 1.1 and higher
- The *connector type B* is suitable only for temporary data exchange and not for permanent connection.
- Max. wire length 5 m (16.4')

CAN bus 2.0B interface

- As per ISO 11898 standard, 50 kBit/s to 1 MBit/s
- Protected against transients (automotive classification)

4 PRODUCT DESCRIPTION

- Max. 110 participants
- Max. wire length 250 m (820 ') depending on the transfer rate

RS485 Interface

- According to TIA-485-A (03/2003)
- Max. 32 participants
- Max. data transfer rate 9.6 kBit/s to 115.2 kBit/s
- Max. wire length 100 m (328') depending on the transfer rate

4.1.7 Requirements for External Equipment

External equipment shall fulfill the input and output specifications of the MIC3.

4.1.8 Overview Drawings

The connectors shown correspond to the standard MIC₃ version.

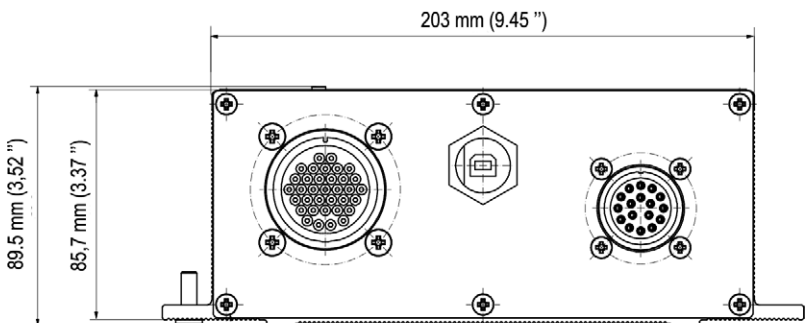
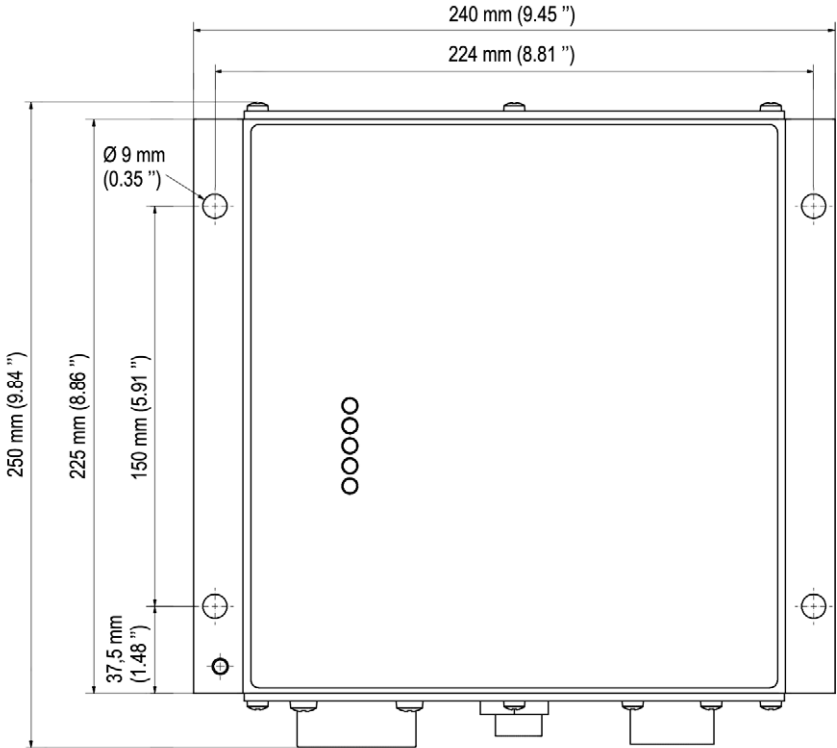

4 PRODUCT DESCRIPTION

LED functions

- Status
- Firing
- Pickup 1
- Pickup 2
- GPO

Labeling	Function
Status	LED flashes green if the device is running with no errors. The LED is illuminated red if an error has occurred. The LED is illuminated yellow if a warning has been issued.
Firing	LED lights up when the ignition is active.
Pickup 1 and 2	LEDs flash when the pickups are active.
GPO	LED is on when the GPO is activated.

USB connection

A USB connection is located at the front of the device to connect the MIC₃ to a PC.

5 INSTALLATION INSTRUCTIONS

5.1 Unpacking

Unpack the equipment, taking care not to damage it, and ensure that the operating manual is always stored with the ignition controller and is easily accessible. Check the contents for completeness and verify that the device type meets your application requirements.

Scope of Supply

The scope of supply of the MIC₃ ignition controller consists of the following components:

- Ignition controller of the MIC₃ series
- Installation set incl. four vibration dampers
- Ground strap
- Three multiple sealing inserts and five sealing plugs for PG screw joints
- CD-ROM with software for configuring the ignition controller
- USB interface cable for connecting the ignition controller to a PC/laptop
- Operating Manual

5.2 Installation of the Ignition Controller

The installation of the MIC₃ ignition controller is implemented on a fixed bracket, e. g. on a wall near the engine, . Use the . The installation location of the controller must be selected so that the distance to the pickups installed on the engine ensures a reliable signal transmission to the ignition controller, and so that there is adequate space for maintenance and repair work. The mechanical specifications must always be complied with (refer to *Mechanical Data* on page 14). The ground strap serves to ground the ignition controller and must be used accordingly. Ensure a flawless electrical connection for this purpose.

Installation locations where strong vibrations or extreme ambient temperatures are present are not permissible and result in the warranty being voided. The permissible temperature ranges are:

-40 °C (-40 °F) to +60 °C (+140 °F)



Risk of damage!

The device must not be installed directly on or at the engine, as vibration and heat may cause damage to electronic components.

5 INSTALLATION INSTRUCTIONS

5.3 Determine the Installation Location of the Pickup

Set the positions of the pickups depending on engine type and application. All angle reference information is based on:

TDC 1st cylinder /Compression cycle

The installation location for the pickups must have adequate mechanical strength and must not exceed the specified temperature ranges. The pickups are designed for the appropriate use only, multiple use of the pickup signal is not permissible. Ensure good accessibility to facilitate the calibration of the sensor. Comply with the pertinent regulations for the wire routing.

For the exact positioning of the individual pickups, refer to the examples given in the drawings (see section *Input Wiring – Pickups* on page 26).

6 WIRING OF THE DEVICE

6.1 Input and Output Wiring on the Controller



Operational safety!

All connector screws and screw joints must be adequately tightened.



Assignment of the wire colors

Take the assignment of the wire colors of the wiring harness for the input and output wiring from the wiring plan enclosed with the wiring harness.

6.1.1 Input Wiring

Input connector

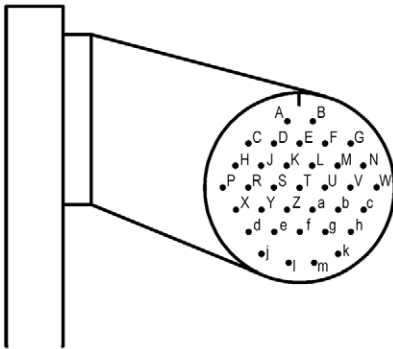

35-pole input connector (outside view)

6 WIRING OF THE DEVICE

Assignment of the connections

Pin	Assignment	Pin	Activation
A	24 V	V	ASO Out
B	Ground	W	ASO GND
C	PU1 Power	X	Shield
D	PU1 Signal	Y	Tx High
E	PU1 Com	Z	Tx Low
F	PU1 Shield	a	GND
G	PU2 Power	b	Rx High
H	PU2 Signal	c	Rx Low
J	PU2 Com	d	Analog GND
K	PU2 Shield	e	Analog PWR
L	CAN High	f	I In -
M	CAN GND	g	I In +
N	CAN Low	h	Analog Shield
P	CAN Shield	j	Start/Stop In
R	Go/NoGo High	k	Sched. A/B In
S	Go/NoGo Low	l	GPI1
T	GPO High	m	Digital GND
U	GPO Low		

6.1.2 Input Wiring – Power Supply

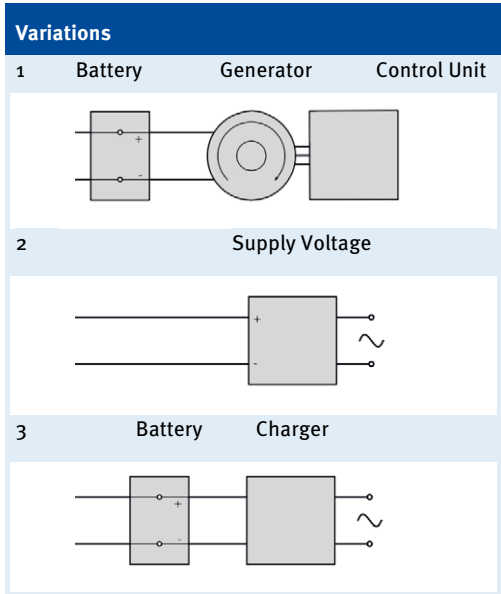
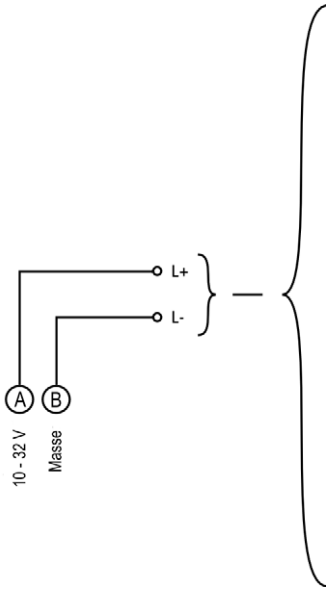

6 WIRING OF THE DEVICE

6.1.3 Input Wiring – Pickups

Example configuration (one active, one passive pickup)

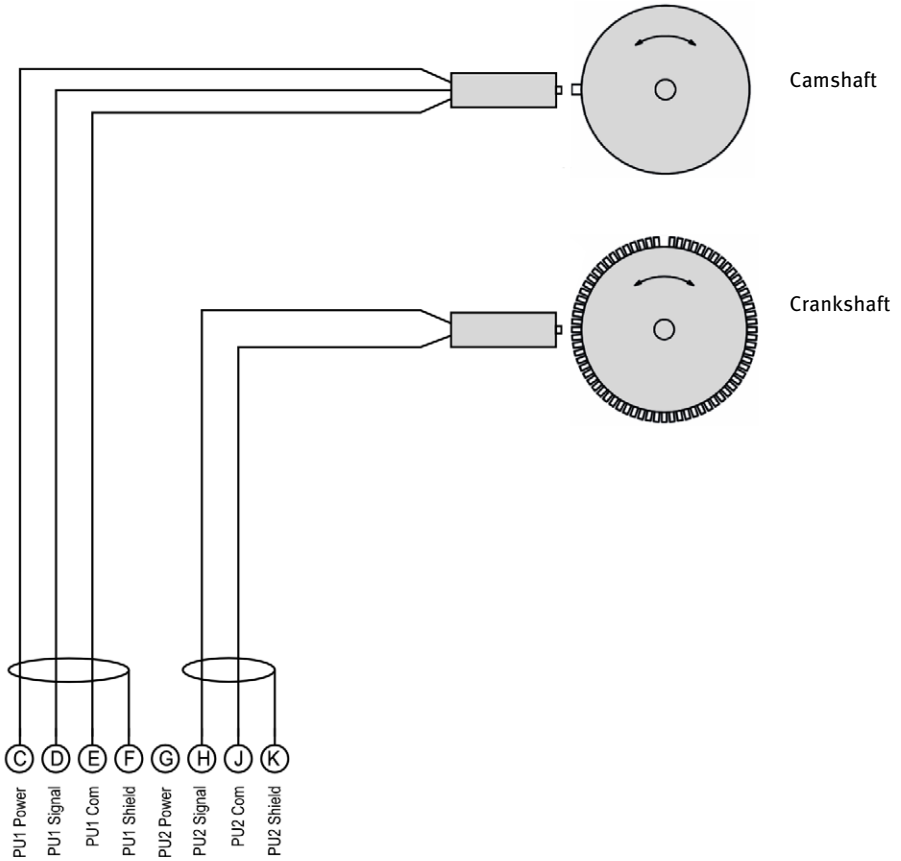

The recommended distance to the triggering is 0.75 mm to 1 mm (0.03 " to 0.04 ") for MOTORTECH pickups. Please note that additional fine-tuning is required for every pickup position due to the different conditions of the engines.

One revolution of the pickup changes the distance as follows:

Thread	Change in distance
M12x1	1 revolution \triangleq 1 mm (0.04 ")
5/8"-18 UNF	1 revolution \triangleq 1.41 mm (0.05 ")
3/4"-16 UNF	1 revolution \triangleq 1,59 mm (0,06 ")

Allocation of the Wire Colors (Example Configuration)

Camshaft

PIN	Designation	Wire color
C	PU1 Power	brown
D	PU1 Signal	black
E	PU1 Com	blue
F	PU1 Shield	shield

Crankshaft

PIN	Designation	Wire color
H	PU2 Signal	white
J	PU2 Com	brown
K	PU2 Shield	shield

For problems with the pickup signal, refer to the section *Pickup Input Errors* on page 132.



Adjusting the pickup sensitivity

Depending on the type of impulse source (interference), it may be necessary to increase the pickup sensitivity to ensure that the resultant signal strength is sufficient for reliable operation. You can make these adjustments in the MICT. Refer to the section *Engine – Pickups* on page 72.



Aux. Pickup Supply Voltage

An auxiliary supply voltage for active pickups can be configured using the MICT. The voltage can be set in the range from 5 to 24 V and is supplied at the connections *PU1 Power* and *PU2 Power*. Refer to the section *Engine – Pickups* on page 72.

6 WIRING OF THE DEVICE

6.1.4 Input Wiring – Ignition Timing and Safety Devices

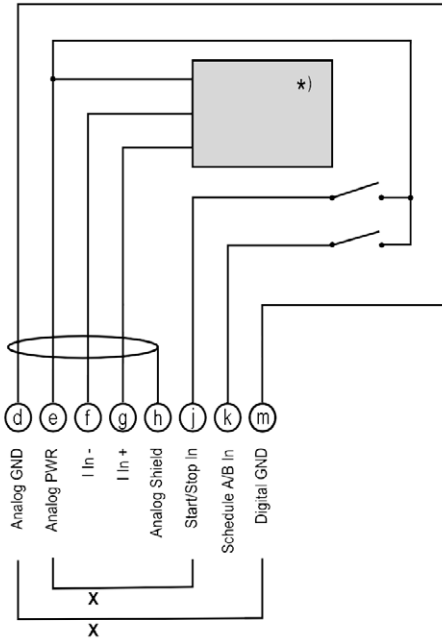

*) For details, see Subsequent Drawings

x = bridge for permanent authorization

Switch Start/Stop

open Ignition – OFF

closed Ignition – ON

Switch A/B

open Schedule A

closed Schedule B

Switch GPI1

1 sec. Reset CAN driver

5 sec. Reset MIC3

Two-wire transmitter

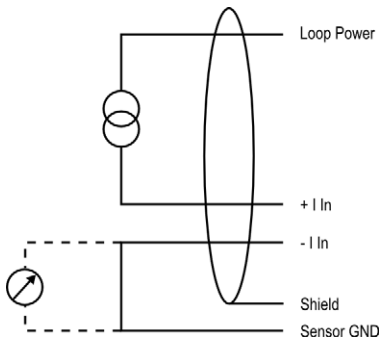

Four-wire transmitter

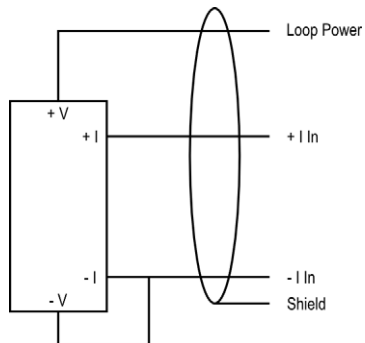



Aux. analog input supply voltage

An auxiliary supply voltage for the analog inputs can be configured using the MICT. The voltage can be set in the range of 5 to 24 V and is made available on the connection *Analog PWR*. If using current transmitters *analog PWR* is used for *loop PWR* and *analog GND* is used for *sensor GND*. Please refer to the section *Timing – Analog Inputs* on page 76.

6.1.5 Output Wiring – Digital Outputs (Go/NoGo, GPO, ASO)

Example configuration

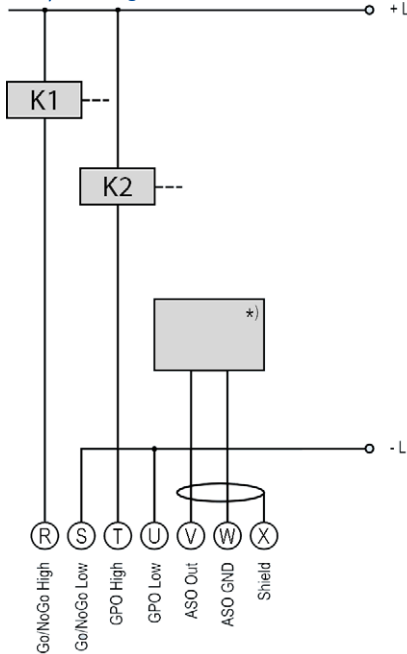

*) DetCon or other external device (for wiring of the DetCon, see following example)

K1 = Go/NoGo relay

K2 = GPO relay

L $\hat{=}$ 7 to 32 V DC

6 WIRING OF THE DEVICE

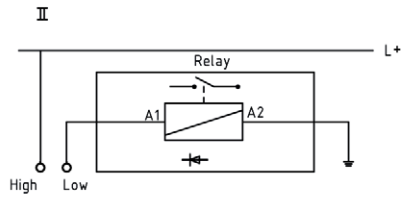
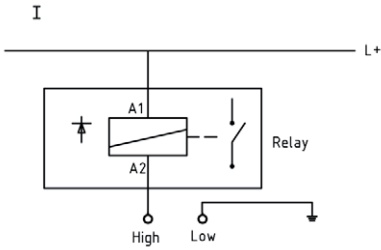

(L \triangleq 7 to 32 V DC)



DetCon connection

Connect the ASO output on the DetCon on the connections *Timing 1* and *Timing 2* on connector *Ignition Pulse*.

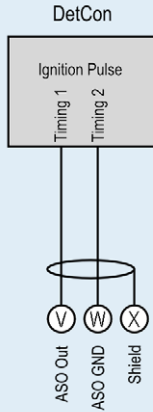

6.1.6 Output Wiring – PowerView3

Connect the MOTORTECH PowerView3 visualization unit to the MIC3 as follows.

CAN Connection between Ignition Controller and PowerView3

As shown in the following illustration, you can connect the PowerView3 directly to the MOTORTECH ignition controller using the CAN cable delivered with the PowerView3. To do so, you need to insert the connector in the CAN interface on the PowerView3. On the ignition controller, connect the color-coded conductors of the CAN cable to the CAN interface.

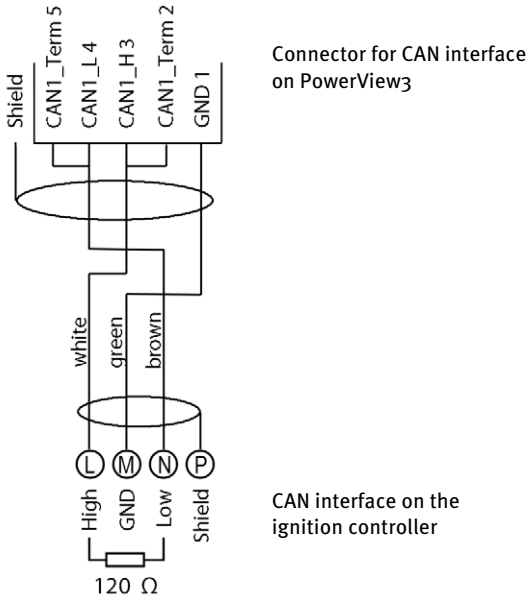

6 WIRING OF THE DEVICE

6.1.7 Output Wiring – CAN Bus – Interface

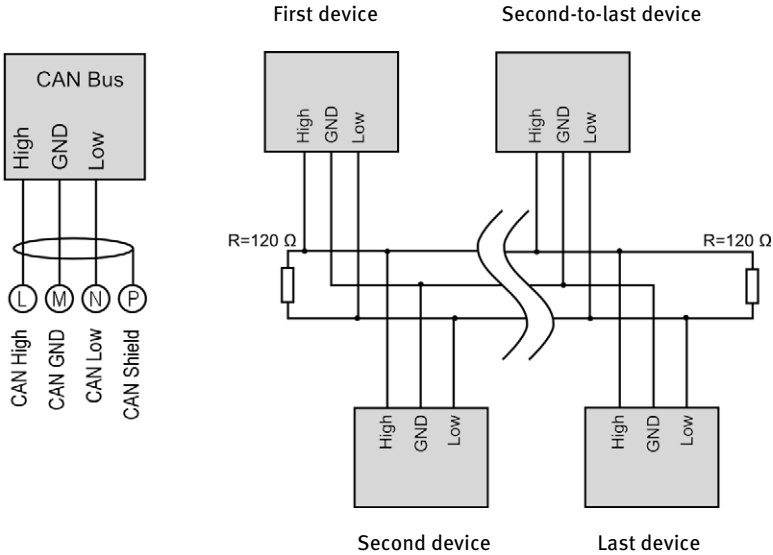

CANopen protocol

If you require information on the CANopen protocol, please contact your MOTORTECH contact person.



CAN bus wiring

Note the following when connecting the CAN bus:

- There can be a maximum of 110 devices connected to one CAN bus.
- The maximum wire length is 250 m (820 ') depending on the transfer rate.
- Each bus end must be fitted with a terminating resistor of 120 Ω (see drawing).

6.1.8 Output Wiring – RS485 Interface

The RS485 interface can be wired as two-wire or four-wire wiring and twisted cables must be used. With both variants the load resistance ($R_T=120\ \Omega$) is the characteristic impedance of the cable.

Two-Wire Wiring

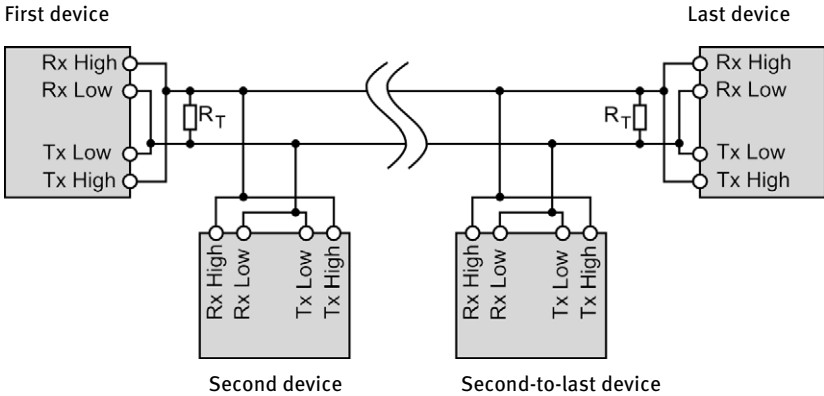

Four-Wire Wiring

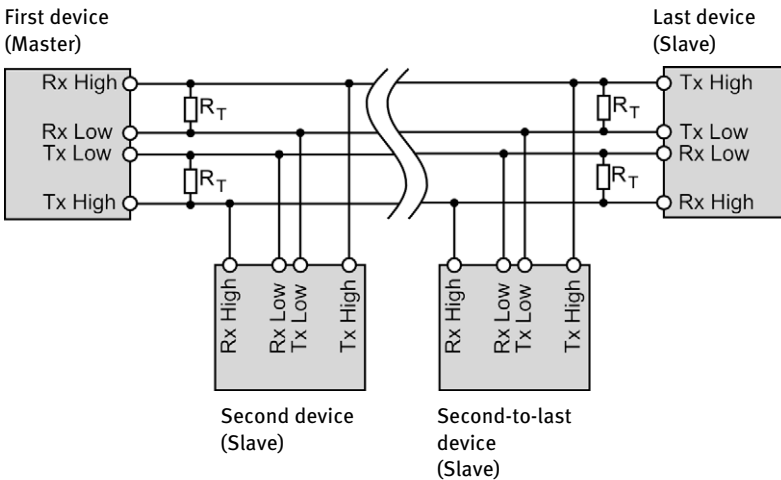

6 WIRING OF THE DEVICE

Connection on the Ignition Controller

The RS485 interface is wired using the 6-pin plug.

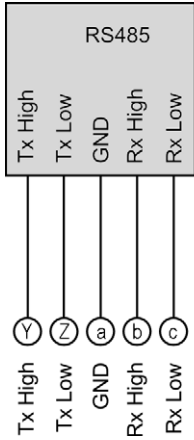

Wiring of the RS485 interface

Follow these instructions for the RS485 interface wiring:

- Max. 32 devices can be connected to a bus.
- The maximum wire length is 100 m (328 ') depending on the transfer rate.
- Each bus end must be fitted with a terminating resistor with 120 Ω (as indicated in the drawing).

6.2 Ignition Coil Wiring



Protection when using wiring rails

Every wiring rail on the engine block should be grounded to avoid disruptions in the device caused by secondary current in the ignition coils.



Ignition Coil Wiring

In the MICT there are two types of wiring with predefined output configuration supported in the engine database for many engines:

- wired in straight order
- wired in firing order

For information on straight order wiring refer to *Straight Order Wiring of the Ignition Outputs* on page 36 and *Engine – Parameters* on page 64.

For wiring in firing order, the first cylinder in the firing order is connected to the A1 output, the second to A2, etc.

If a different wiring was implemented, the output configuration in the MICT must be adapted accordingly. Please note that the wiring cannot be checked by the software (refer to *Engine – Parameters* on page 64).

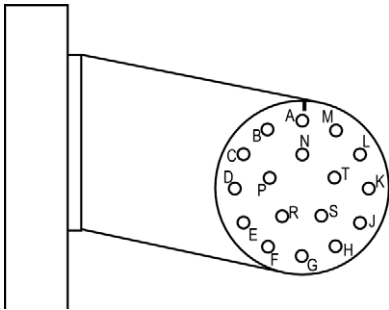

17-pole connector (Outside view)

The table shows the pole assignments for the standard 6 and 12 cylinder versions of the MIC3.

Pin	12 outputs	6 outputs
A	Output A1	Output A1
B	Output A2	Output A2
C	Output A3	Output A3
D	Output A4	Output A4
E	Output A5	Output A5
F	Output A6	Output A6
G	Output A7	not assigned
H	Output A8	not assigned
J	Output A9	not assigned

6 WIRING OF THE DEVICE

Pin	12 outputs	6 outputs
K	Output A10	not assigned
L	Output A11	not assigned
M	Output A12	not assigned
N	not assigned	not assigned
P	not assigned	not assigned
R	not assigned	not assigned
S	not assigned	not assigned
T	Ground	Ground

6.3 Straight Order Wiring of the Ignition Outputs



Risk of damage to engine

If you use straight order wiring, it is absolutely necessary that the MOTORTECH wiring rail for the respective engine is used and correctly installed. Even a rotated installation can cause serious damage to the engine, for example.

Straight order wiring, along with wiring in firing order, is supported by the MICT for many engines with predefined output configurations in the engine database. That means that if the wiring is carried out accordingly and the option *Wired in Straight Order* is selected in the MICT, no other adaptation of the output configuration is necessary.

You can use straight order wiring, if:

- wiring is done via a corresponding MOTORTECH wiring harness (this is marked with the following notice: CAUTION! Firing Order needs to be configured directly with Ignition Controller.).
- Make the wiring of the ignition controller corresponding to the instructions in the following sections (for example with an open wiring harness or via a junction box).

The execution of straight order wiring is dependent on the type of engine (in-line or V engine).

Version with 6 outputs

Pin	6 outputs	In-line engine	V engine
A	Output A1	S1 Sp 1	S1 Sp 1
B	Output A2	S1 Sp 2	S2 Sp 1
C	Output A3	S1 Sp 3	S1 Sp 2
D	Output A4	S1 Sp 4	S2 Sp 2
E	Output A5	S1 Sp 5	S1 Sp 3
F	Output A6	S1 Sp 6	S2 Sp 3
G	–		
H	–		
J	–		
K	–		
L	–		
M	–		
N	–		
P	–		
R	–		
S	–		
T	Ground		

S = connector on the wiring rail

Sp = ignition coil with the corresponding number on the wiring rail

6 WIRING OF THE DEVICE

Version with 12 outputs

Pin	12 outputs	In-line engine	V engine
A	Output A1	S1 Sp 1	S1 Sp 1
B	Output A2	S1 Sp 2	S2 Sp 1
C	Output A3	S1 Sp 3	S1 Sp 2
D	Output A4	S1 Sp 4	S2 Sp 2
E	Output A5	S1 Sp 5	S1 Sp 3
F	Output A6	S1 Sp 6	S2 Sp 3
G	Output A7	S1 Sp 7	S1 Sp 4
H	Output A8	S1 Sp 8	S2 Sp 4
J	Output A9	S1 Sp 9	S1 Sp 5
K	Output A10	S1 Sp 10	S2 Sp 5
L	Output A11	S1 Sp 11	S1 Sp 6
M	Output A12	S1 Sp 12	S2 Sp 6
N	–		
P	–		
R	–		
S	–		
T	Ground		

S = connector on the wiring rail

Sp = ignition coil with the corresponding number on the wiring rail

7 FUNCTIONS

The ignition controllers of the MIC3 series include freely configurable safety and auxiliary functions that, amongst others, can shut down the engine in case of fault.



Angle indications in the operating manual

All angles in this operating manual are given in °crankshaft. Exceptions are clearly identified.

7.1 Pickup Sensitivity

To increase the signal interference distance, the sensitivity of the pickup signal inputs can be changed for suitable pickup signals. This setting can be implemented individually for each input. For this purpose, a pre-trigger voltage can be set below which signals are interpreted as interference and are therefore not analyzed. A pre-trigger voltage set to a high level will thus result in a low pickup sensitivity level.

You can enter the settings for the pickup sensitivity with the MICT. Refer to the section *Engine – Pickups* on page 72.

7.2 Monitoring of Pickup Signals

The MIC3 monitors the pickup signals. Any other errors are displayed in the MICT. For further information on errors, please refer to the overview in section *Causes of Typical Errors* on page 133.

7.3 Go/NoGo

The MosFET output (Go/NoGo) is a potential-free output. It is closed during firing and opens when the ignition switches off. The maximum switching current is 100 mA. The output can drive an external relay that, for example, opens a gas valve.

The following errors can cause the ignition outputs to shut down:

- Overspeed
- Pickup error
- Error HV power supply
- Failure of the output monitoring
- Overload / temperature shut-down
- Alarms
- Insufficient supply voltage (Low Power)

7 FUNCTIONS

7.4 Timing Correction

The ignition controller has several functions for the timing correction.



Influencing the ignition timing

Please be aware that the actual timing of the engine can also be influenced by external signals (e. g., analog current or voltage input).



Operational safety

The MIC₃ ignition controller must first be correctly configured for the engine being used before you can start the engine.

An incorrect configuration can result in damage to the engine.

The figure below gives you an overview of the different functions of the timing correction, which will be explained in more detail in the subsequent sections. Functions that can be activated/disabled via the MICT are marked by a switch symbol.

Per schedule:

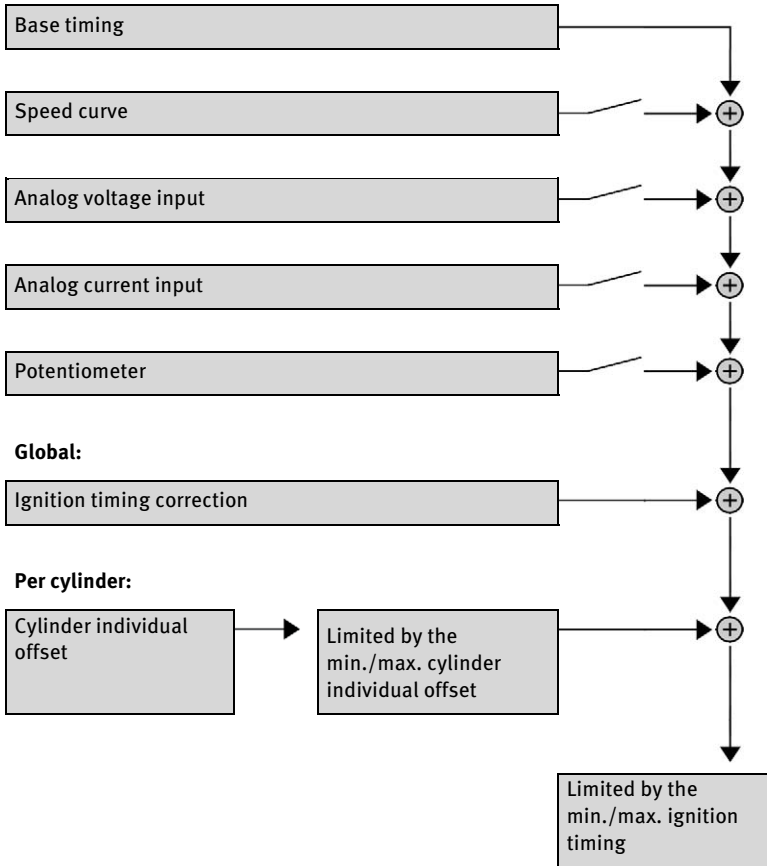

7.4.1 Analog Inputs

The timing point control can be adjusted with a linear current signal. This signal can be supplied, for example, by a potentiometer, a pressure sensor for charging pressure, or a detonation controller.

With the analog process signal (current loop signal) at the analog current input, the timing point can be offset in the advanced or retarded direction within a defined range.

Similarly or additionally, the timing can also be influenced by an analog voltage signal at the corresponding input.

7 FUNCTIONS

The levels of the analog inputs can be set in the range from 0 to 20 mA and 0 to 10 V. You can make this configuration with the MICT. Please refer to the section *Timing – Analog Inputs* on page 76.

At the voltage output (*Analog PWR*), a configurable auxiliary voltage is supplied that can be used for supplying power to external sensors.



Sample configurations

In this example the analog inputs are configured in the *Timing – Analog Inputs* window as follows:

- Input current: 4-20 mA
- Input voltage: 0-5 V

Characteristic 4-20 mA / 0-5 V – Timing correction toward *retarded*.

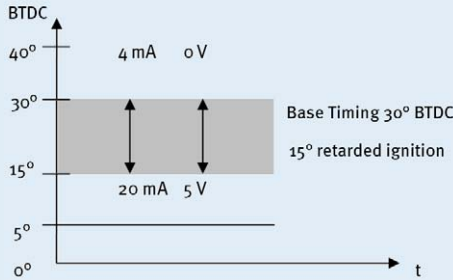

Characteristic 4-20 mA / 0-5 V – Timing correction toward *advanced*.

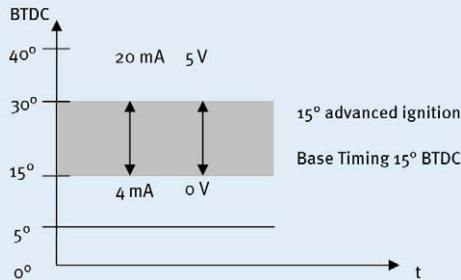

7.4.2 Cylinder-to-Cylinder Alignment

The cylinder-to-cylinder alignment enables the user to change the timing for individual cylinders to optimize their combustion.

You can enter the settings for the cylinder-to-cylinder alignment with the MICT. Please refer to the section *Cylinder Individual Offsets* on page 119.



Use of measuring unit

Use this setup option only if no suitable measuring unit is available for determining the optimum timing point, so that the result of a change can be assessed immediately.

7.4.3 Speed Curve

To optimize the ignition, for example, during the start phase of the engine, a speed curve can be defined for the MIC₃ ignition controllers. To create this curve, up to eight adjustable speed points are available.

You can configure the speed curve with the MICT. Refer to the section *Timing – Schedule A/B – General* on page 78.

7.4.4 Timing Correction

There are two options for making corrections to the ignition timing:

- CANopen/Modbus/J1939
The field buses can be used to adjust the cylinder individual ignition timing points in 0.1° increments by max. +/- 12.5° crankshaft, restricted by the ignition timing point limits of the current schedule.
- MICT via USB
Please refer to the section *Runtime Adjustments – Timing* on page 114.

7.5 Firing angle

The min. distance between two ignition angles depends on the overspeed. The smallest ignition spacing can be calculated using the following formula:

$$\text{Ignition Angle} = \frac{\text{Overspeed} [\text{min}^{-1}]}{60} \times 360^\circ \times 2,8 \text{ ms}$$

7.6 HV-Power Supply Error Monitoring

The voltage applied is monitored for excess voltage or low voltage by the integrated power supply. For both errors a Power-Fail error is saved and the device shuts off.

7 FUNCTIONS

7.7 Schedules A/B

The MIC₃ ignition controllers offer two separate schedules for the parameterization of the ignition timing and energy.

By closing input *Schedule A/B*, the listed parameter settings for schedule B can be selected. A possible application for this is e. g. operation with different gases. If only one schedule is configured, this is used regardless of the switch position.

You can configure the schedules with the MICT. Please refer to *Timing – Schedule A/B – General* on page 78 and *Timing – Schedule A/B – Energy* on page 80.



Operational Safety

If you use schedules A and B, the advanced timing point should be linked to schedule B (switch closure). If a wire ruptures, schedule A is automatically selected with the retarded (and thus safer) timing point.

7.8 Alarms

The MIC₃ ignition controllers include 16 freely configurable alarms in total. These alarms can be freely allocated to the general purpose output (GPO) and set depending on the following functions:

- Limit for speed exceeded / not reached
- Limit for engine operating hours exceeded / not reached
- Limit for spark plug operating hours exceeded / not reached
- Warning active
- Error active
- Limit for temperature exceeded / not reached
- Limit for supply voltage exceeded / not reached
- Limit for global ignition timing exceeded / not reached
- Limit on the analog voltage input exceeded / not reached
- Limit on the analog current input exceeded / not reached
- Limit of the minimum spark duration exceeded / not reached
- Misfire rate (primary, single output) over limit
- Misfire rate (primary, all outputs) over limit
- Misfires per second (primary, all outputs) over limit
- Consecutive misfires (primary, single output) over limit
- Misfire rate (secondary, single output) over limit

- Misfire rate (secondary, all outputs) over limit
- Misfires per second (secondary, all outputs) over limit
- Consecutive misfires (secondary, single output) over limit

A hysteresis can be defined for some alarms. You can configure the alarms with the MICT. Refer to the section *Inputs/Outputs – Alarms* on page 82.

7.9 GPO: General Purpose Output

The function of the general purpose output (GPO) can be set as desired as normally closed or normally open. The GPO can be used for the freely definable alarms.

You can enter the settings for the general purpose output with the MICT. Refer to the section *Inputs/Outputs – Alarms* on page 82.

7.10 ASO: Auxiliary Synchronization Output

The ASO is an output of the MIC₃ for synchronizing the MIC₃ ignition controller and a connected control unit. The possible applications include detonation control, valve control, and fuel injection control.

The ASO signal is Low-Active, i. e. the pulse width is defined as the time difference between the raising and falling edge (pulse width = $t_{\text{raising}} - t_{\text{falling}}$). The raising edge of the signal marks the configured engine rotation angle. With the variable pulse width, the values can be allocated to the engine rotation angle. A max. of 16 pulses can be configured for this purpose.

The pulse width is known at the time of the active edge, as the falling edge of the signal precedes the raising edge by the value of the pulse width. The controller calculates the duration of the falling edge from high-level to low-level and then back to the starting value of the high-level.

You can configure the auxiliary synchronization output with the MICT. Refer to the section *Inputs/Outputs – ASO₁ (auxiliary synchronization output)* on page 84.



Application of the ASO signal

The following example will illustrate the application of the ASO signal:

- Four-stroke engine with 6 cylinders
- Ignition angle $120^\circ - 120^\circ$

Synchronization between MIC₃ and Valve Controller

Cyl.	Ignition angle in °crankshaft	ASO signal in °crankshaft	Pulse duration in μs
1	0/720	718	160
2	120	118	80
3	240	238	80
4	360	358	80
5	480	478	80
6	600	598	80

Schematic Representation

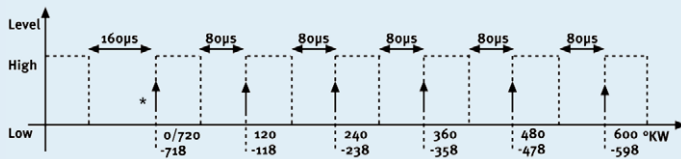

*) active edge

The valve controller should receive the active edge of the ASO signal before the top dead center of a cylinder. The first pulse duration should be twice as long and thus mark the beginning of a cycle. The ASO signal generated by the MIC₃ increases by 2° each time before the ignition signal from Low to High, as can be seen in the schematic drawing. This edge is analyzed by the valve controller as the active edge.

The ASO signal drops in accordance with the configured pulse duration from High to Low before the active edge. The valve controller then has already measured the pulse duration of the active edge and can provide information on the allocation of the signal. In the example shown here, the first cylinder is marked with a pulse width of $160 \mu\text{s}$ versus $80 \mu\text{s}$ for other cylinders. If the valve controller measures a pulse width of $160 \mu\text{s}$, the subsequent signal is therefore allocated to the first cylinder. The next signal then corresponds with the second cylinder in the ignition sequence, etc.

7.11 Ignition Energy

The ignition energy can be set separately for the start phase and normal operation. Here different settings can be made for schedules A and B.

You can configure the ignition energy with the MICT. Refer to the section *Timing – Schedule A/B – Energy* on page 80.

7.12 Access Control

The MIC3 has four operating levels, three of which can be secured with different PINs. As a default setting, the access control is not activated. If the access control for the MIC3 is activated, it is independent from the access levels that control authorizations within the MICT.



Access control in the MICT and on the MIC3

A user is logged in to the *Advanced Service* access level on the MICT. He changes a configuration and would like to download the change to the MIC3. Although he has the full authorization set in the MICT, he is prompted to log in with the PIN for the *Level 3 (Master)* on the MIC3.

A variety of functions are at your disposal in the four MIC3 operating levels. The figure below illustrates this:

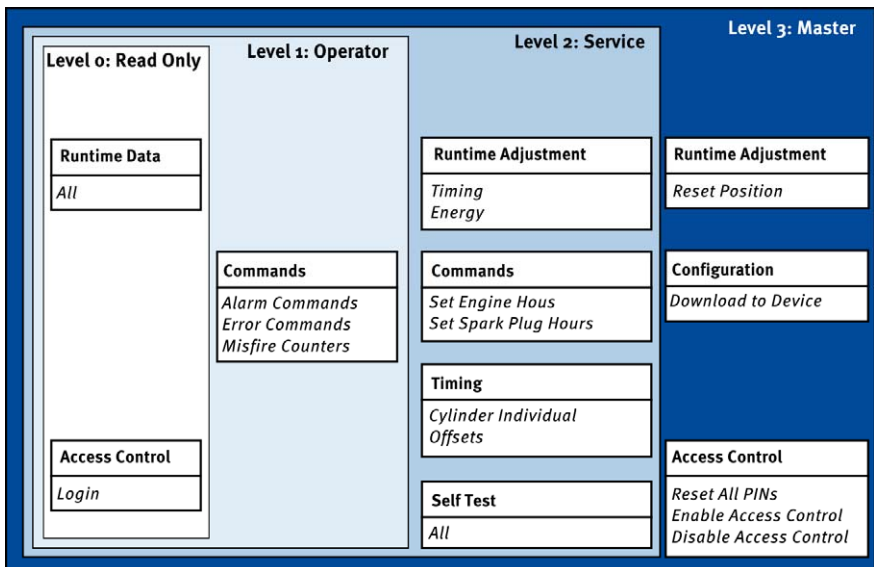

7 FUNCTIONS

The following functions are available on the different levels:

- **Level 0 (Read Only)**
Enables read only access for all users.
- **Level 1 (Operator)**
The user can operate the Alarm Commands, Error Commands, and the Misfire Counter on this level.
- **Level 2 (Service)**
Only the Service level has access to modifications of the runtime adjustments for Timing and Energy and the commands Set Engine Hours, Set Spark Plug Hours. The Cylinder Individual Offsets and the Settings for Self Test can also be executed in this operating level.
- **Level 3 (Master)**
On this level, the Master can, in addition to the other adjustments, modify the Reset Position and Reset All PINs and Enable/Disable Access Control. This authorization is also needed to transfer a configuration to an ignition controller.

For information on the access levels in the MICT, please refer to the section *Access Levels in the MICT* on page 50.

8 SETTINGS VIA THE MICT

MICT is an abbreviation for *MOTORTECH Ignition Configuration Tool*. With the MICT, you can configure your ignition controller, and you can view and adjust the operating data of your engine.

8.1 MICT System Requirements

For the installation of the MICT, the following minimum requirements must be fulfilled:

- x86-compatible PC, minimum performance category Intel Pentium 4 with 2 GHz
- 128 MB free RAM
- 100 MB free disk space
- USB interface 1.1 or higher
- Display with minimum XGA resolution (1024 x 786 pixels)
- Microsoft Windows XP, Windows 7

8.2 MICT Installation

The software for the installation of the MICT is on the CD-ROM enclosed with the ignition controller.

To install the MICT, proceed as follows:

1. Start the installation.
 - CD-ROM as installation medium
Insert the CD-ROM in the CD/DVD drive of your PC. If the Autorun function is activated for the drive, the installation will start automatically. If the function is disabled for the drive, the installation routine can be started with the file *setup.exe* from the CD-ROM directory.
 - Alternative
Copy the installation routine *setup.exe* to your PC. The installation is started by executing the file.
2. Run the installation.
Follow the instructions of the installation routine. Please note that the license agreement terms must be accepted before using the MICT. If the terms are not accepted, the installation cannot continue.
3. Install the USB driver by running the file *CDMxxxx_Setup.exe* (e.g. *CDM20824_Setup.exe*).
 - ▶ The MICT is now set up. You can connect your PC to the ignition controller via the USB interface.

8 SETTINGS VIA THE MICT

8.3 Access Levels in the MICT

You can open the MICT via *Start -> Programs -> MOTORTECH -> MICT -> MICT* on your PC.

After opening the MICT, select the access level for which you have clearance. The access level controls the options you have at your disposal in the MICT. The password required for access can be obtained from your MOTORTECH contact person (refer to *Customer Service Information* on page 135).



The following access levels are available:

- **Read Only**
On this level, the user can open a configuration and transfer it to the device. However, he cannot make changes to the configuration. The user has read-only access to all other settings.
- **Customer**
This level enables the configuration of the basic functions required for operation in addition to the read-only function.
- **Service**
This level contains all functions for a standard installation.
- **Advanced Service**
This level offers full access to all functions of the MICT and is enabled and accessible for specially trained personnel only.

The following sections will describe the options at your disposal with the *Advanced Service* access level. If you have registered for a different level, you cannot execute all functions shown.

8.4 Configuration Pages (Overview)

The configuration pages are divided into the following sections:

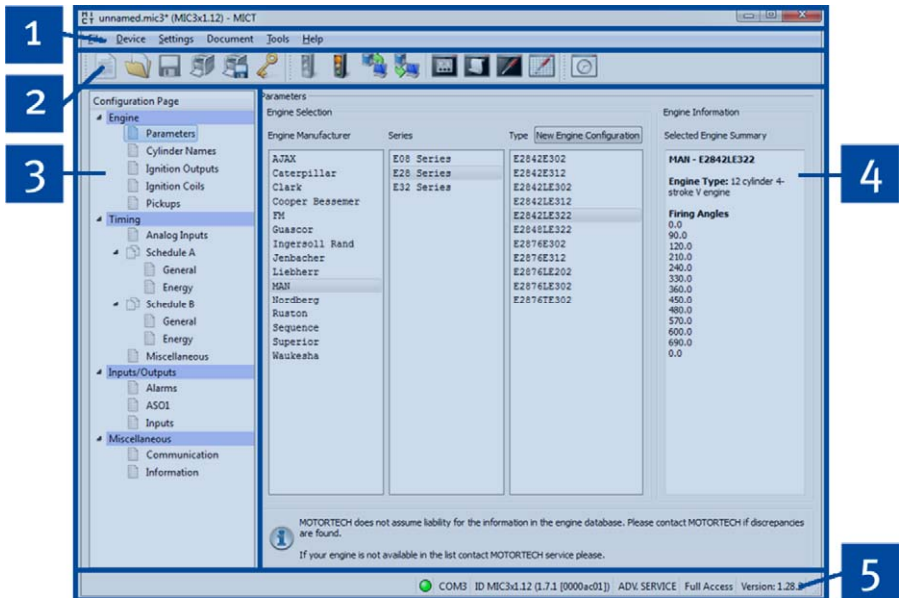

Item no.	Area
1	Menu Bar
2	Toolbar
3	Navigation bar
4	Configuration section
5	Status bar

The functions in the menu bar, navigation bar and the toolbar as well as the configuration section will be described in the following.

The status bar provides you with the following information (from left to right):





- Status Display
Indicates whether a connection is established with the controller:
 - Green: Connection established







8 SETTINGS VIA THE MICT

- Red: The connection was interrupted and is being restored
- Gray: The connection is not established and is not being restored
- Indication of the interface being used for the connection to the device
- Indication of the device ID
- Indication of the access level of the user in the MICT
- Indication of the operating level for the MIC₃ if the access control feature was activated and the user has logged in with a PIN
- Indication of the MICT program version

8.5 Menu Bar and Toolbar

The following functions are available to you via the symbols on the toolbar and the entries in the menu bar:

Symbol	Menu	Function
	<i>File -> New</i>	Creates a new configuration.
	<i>File -> Open</i>	Opens an existing configuration.
	<i>File -> Save / File -> Save As</i>	Saves the current configuration.
	<i>File -> Close</i>	Closes the current configuration.
	<i>File -> Open trace</i>	Opens a runtime data record (trace file). Please refer to the section <i>Runtime Data</i> on page 89.
	<i>File -> Open pickup trace</i>	Opens a saved record of pickup signals (putrace file). Refer to the section <i>Pickup - Trace</i> on page 57.
	<i>File -> Change Access Level</i>	Changes the MICT access level for accessing the configuration data and functions.
	<i>File -> Print</i>	Prints the current configuration.

Symbol	Menu	Function
	<i>File -> Print to PDF File</i>	Prints the configuration to a PDF file.
	<i>File -> Print Preview</i>	Opens a print preview of the configuration.
	<i>File -> Quit</i>	Exits the MICT.
	<i>Device -> Connect</i>	Connects to the device.
	<i>Device -> Disconnect</i>	Cuts the connection to the device.
	<i>Device -> Download to device</i>	Downloads configuration data from the PC to the device. Refer to <i>Working with Configurations</i> on page 61.
	<i>Device-> Upload from Device</i>	Uploads configuration data from the device to the PC. Refer to <i>Working with Configurations</i> on page 61.
	<i>Device -> Runtime data</i>	Opens the window <i>Runtime data</i> . Please refer to the section <i>Runtime Data</i> on page 89.
	<i>Device -> Log</i>	Opens the window <i>Log (Advanced Service only)</i> . Please refer to the section <i>Log</i> on page 111.
	<i>Device -> Runtime adjustments</i>	Opens the window <i>Runtime Adjustments (Service and Advanced Service only)</i> . Please refer to the section <i>Runtime Adjustments</i> on page 112.
	<i>Device -> Cylinder individual offsets</i>	Opens the window <i>Cylinder Individual Offsets (Advanced Service only)</i> . Please refer to the chapter <i>Cylinder Individual Offsets</i> on page 119.
	<i>Device -> Self test</i>	Opens the window <i>Self Test (Service and Advanced Service only)</i> . For this read section <i>Self Test</i> on page 56.
	<i>Device -> Pickup trace</i>	Loads the automatically recorded pickup signals from the device. Refer to the section <i>Pickup -Trace</i> on page 57.

8 SETTINGS VIA THE MICT

Symbol	Menu	Function
	<i>Device -> Set spark plug operating hours</i>	Opens the window <i>Set spark plug operating hours</i> .
	<i>Device -> Set engine operating hours</i>	Opens the window <i>Set engine operating hours</i> .
	<i>Device -> Set date and time</i>	Opens the window <i>Set date and time</i> , in which you can set the clock in the device.
	<i>Device -> Send command -> Reset misfire counters</i>	The misfire counters of all ignition controller outputs are reset and restarted. Misfires that previously occurred at the outputs are no longer displayed.
	<i>Device -> Send command -> acknowledge operational errors</i>	All operating errors are acknowledged. This can only be implemented while the engine is not running.
	<i>Device -> Access Control</i>	The setup for the access controls for the MIC ₃ are described in a separate section. Please read the chapter <i>Access Control for the MIC₃</i> on page 59.
	<i>Device -> Temperature Extremes</i>	Opens the <i>Temperature Extremes</i> window in which the minimum and maximum temperatures of the controller and output boards are displayed.
	<i>Settings -> Language</i>	Opens the window <i>Select Language</i> in which you can change the interface language of the MICT.
	<i>Settings -> Online update settings</i>	Opens the window <i>Online Update Settings</i> . Please refer to the section <i>Online Update Settings</i> on page 55.
	<i>Settings -> Temperature scale</i>	Opens the window <i>Select Temperature Scale</i> , in which you can change the unit for the temperatures shown in the MICT.
	<i>Settings -> Display by cylinders</i>	Currently not used.
	<i>Document -> Schedule Curve</i>	Opens the window <i>Schedule Curve</i> . Please refer to the chapter <i>Schedule Curve</i> on page 120.
	<i>Tools -> Coils</i>	Opens a database with information on MOTORTECH ignition coils.

Symbol	Menu	Function
	<i>Help -> Help</i>	Opens the online help function.
	<i>Help -> About MICT</i>	Opens detailed information on the MICT.

8.6 Online Update Settings



Perform regular online updates

MOTORTECH is constantly expanding its databases. Perform regular online updates to make optimal use of the opportunities that the MIC₃ provides.

The MICT uses data from an engine database and a coil database for the configuration. Such data can be updated with automatic online updates. The settings for the update can be entered with the following entry in the menu bar:

Settings -> Online update settings

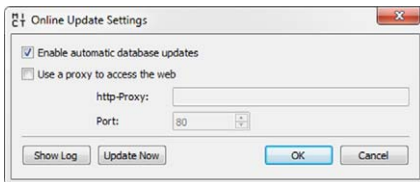

You have the following options:

- [Enable automatic online updates](#)
Use the checkbox to activate and disable the automatic online updates. As the default setting, the online update is activated and is executed daily (if an internet connection is established) at first start-up of the MICT.
- [Use a proxy to access the web](#)
Using the checkbox, you can activate settings for Internet access via a proxy server, which you can then set up by entering *http Proxy* and *Port*.
- [Show Log](#)
Use this button to open a window in which the online updates performed are logged.
- [Update Now](#)
Use this button to manually start an online update.

8 SETTINGS VIA THE MICT

8.7 Self Test



Operational safety!

If you carry out a self-test, it is essential for the gas supply to be switched off and no more residual gas is left in the combustion chamber. Non-compliance can result in damage to equipment or injury to persons.

You can run the self test via the MICT to check the order of the wiring and the connection between the ignition controller outputs and the spark plugs.

Proceed in the MICT as follows:

Device -> Self Test

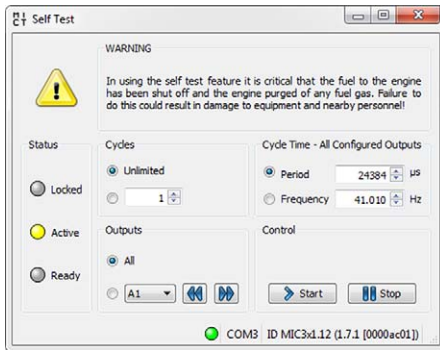

The following information is provided:

Status

The status displays indicate whether the ignition controller is ready for the self test.

Locked The ignition controller is in a state in which no self test can be done. For example, there is an error or a configuration is currently being downloaded into the device.

- **Active**
The self test is running.
- **Ready**
The ignition controller is ready and the self test can be started.

You have the following options:

- **Cycles**
Specify whether the number of cycles is unlimited or set at a specific number.

- **Outputs**
Specify whether *all* outputs or only a defined output should be fired during the self test.
- **Cycle Time - All Configured Outputs**
Specify the cycle time either as a *period* or *frequency*. The value entered always refers to a complete cycle. That means that all outputs that are configured are fired once per cycle. If you only set one output for the self test, this would still only fire once per cycle.
- **Control**
Start or stop a self test using the corresponding buttons.

8.8 Pickup -Trace

The traces of the pickup signals support you in checking the behavior of the used pickup and thus, for example, to detect and analyze irregularities or failures.

Pickup signals are automatically recorded by the ignition controller as soon as they are detected at the configured inputs. If an error occurs during operation, the record is stopped so that the pickup can be analyzed shortly before the error. The records can be downloaded from the device at any time.

Proceed in the MICT as follows:

Device -> Pickup trace



Pickup Trace

Example of a pickup trace for a configuration with two pickups:

- Pickup input 1 (cam):
Single event from the camshaft
- Pickup input 2 (trigger):
Trigger disk type N-1 with 160-1 events from the crankshaft

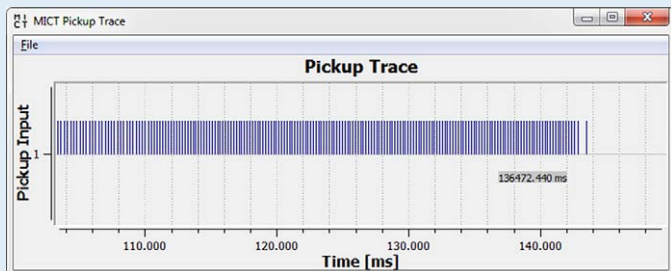

8 SETTINGS VIA THE MICT

Operation

The following options are available via the menu in the window:

- **Open**
Opens a previously saved pickup trace.
- **Save as**
Saves a pickup trace as a .putrace file.
- **Close**
Closes the pickup trace.

There are the following options for the display of the pickup signals:

- **Zoom In/Out**
Using the mouse scroll wheel to zoom in or out of the displayed record range. Alternatively you can also use the plus and minus keys on the keyboard. The Zoom function gives you the option, for example, of also analyzing the trigger signal more precisely (in the Pickup Input figure).

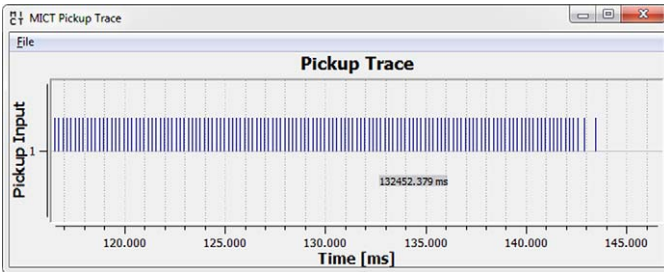

- **Move displayed range**
With the right mouse button pressed you can move the displayed range along the time axis.
- **Measuring**
You can measure distances and the number of events in the displayed range by holding down the right mouse button to highlight a section. You can find the following information in the window:
 - Position on the time axis
 - Time difference (Δ) between the two selected points

- Number of events counted in the selected period

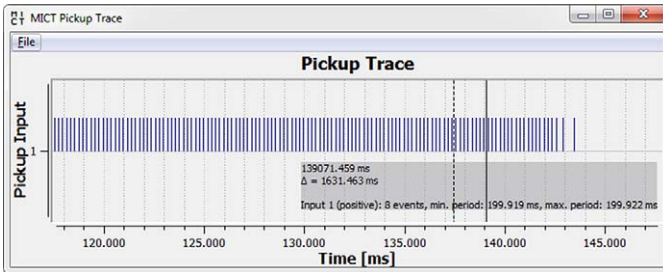

Error analysis

The pickup traces support you, for example, in analyzing the following errors:

- Configuration of the pickup does not agree with the wiring (e. g. trigger disk configuration, allocation of the inputs, allocation of the shafts).
- One or more pickups have failed.



Pickup -Trace

The pickup signals are only recorded on the inputs that are configured in the MICT. No signals are recorded if the pickup input configuration is not valid.

8.9 Access Control for the MIC₃

If the access control to the MIC₃ is activated, access to the following areas is possible with a PIN only:

- **Runtime Adjustment** (Reset, ignition timing, energy, calibration of the secondary voltage estimation and calibration of the secondary short-circuit monitoring)
- **Commands** (Alarms, Error Commands, Set Engine/Spark plug Operating Hours, and Self Test)
- **Configuration** (Transferring a configuration to the MIC₃)

The access control regulates the accesses to the device via the MICT. For explanations concerning access control to the MIC₃ and the delimitation of the access levels in the MICT, refer to section *Access Control* on page 47.

The access control functions can be accessed in the menu bar via:

Device -> Access Control

8 SETTINGS VIA THE MICT

8.9.1 Enabling/Disabling Access Control



Enabling and disabling access control

As a default setting, the access control is not activated, and all PINs are set to 0000. Once the access control has been activated, and the PINs were changed, these PINs will continue to be used. To activate the access control again, you will need the PIN for level 3 (*Master*). It is therefore recommended to reset all PINs before disabling.

If that was not done, or a system must be unlocked for another reason, a request key can be issued in the MICT. Refer to the section *Resetting all PINs* on page 61.

To enable or disable the access control, proceed as follows:

1. Open the input dialog via *Device -> Access Control -> Enable or Disable the Access Control*.
2. Enter the PIN for the level *Master (Level 3)*.
3. Confirm the input with *OK*.

8.9.2 Login/Logout

If the access control is activated, you are prompted to log in if you want to execute functions that are allocated to a specific operating level. In addition, you can log in specifically to an operating level via the menu bar.

To log into a specific operating level, proceed as follows:

1. Open the input dialog via *Device-> Access Control -> Login*.
2. First select the level you wish to log on to.
3. Enter the PIN for the desired level.
4. Confirm the input with *OK*.
 - ▶ You are now logged into the corresponding level and can execute all functions that are allocated to this operating level without having to log in again.

After completing the log-in, you can log out again as follows:

Device -> Access Control -> Logout

8.9.3 Changing the PIN

To change the PIN for a specific operating level, proceed as follows:

1. Open the input dialog via *Device -> Access Control -> Change PIN*.
2. First select the level for which you wish to change the PIN.
3. Enter the current PIN for the desired level.

4. Enter the new PIN in the two subsequent fields.
5. Confirm the input with *OK*.
 - ▶ The PIN for this operating level has now been changed.

8.9.4 Resetting all PINs

To reset all PINs, proceed as follows:

1. Open the input dialog via *Device -> Access Control -> Reset all PINs*.
2. If you are not yet logged into the *Master (level 3)* level, you will be prompted to log in with the relevant PIN.
3. Accept the input with *OK*.
4. To reset all PINs, you will once again be prompted to enter the PIN for the *Master (level 3)* level.
5. Accept the input with *OK*.
 - ▶ All PINs are now reset to the value *0000*.

To reset all PINs, you need the PIN for the level *Master (level 3)*. To be able to unlock a system in case of emergency that was locked in this way, you have the following option:

1. In the menu bar, select the entry *Device -> Access Control -> Get reset all PINs request key* to open a window with the same name.
2. Send the request key with the serial number to your service contact partner at MOTORTECH (refer to *Customer Service Information* on page 135). This key is valid only for the respective controller and only for a certain amount of time.
 - ▶ Your information will be verified, and you will receive an authorization key from your contact partner.
3. Open with the menu entry *Device -> Access Control -> Input of authorization keys to reset all PINs* of the same window name.
4. Enter the authorization key received in the input field.
5. Accept the input with *OK*.
 - ▶ If the input was correct, all PINs are reset to the default value *0000*.

8.10 Working with Configurations

To ensure that the MIC3 correctly interprets incoming data and correctly controls the ignition system, it requires information about the engine and the ignition system. This information is stored in the MIC3 as configuration data.

You can use the MICT to perform the following for these configurations:

- Create
- Open

8 SETTINGS VIA THE MICT

- Edit
- Save as a file
- Download to the MIC₃
- Upload from the MIC₃

8.10.1 Create, Open, Save



Click on the symbol to create a new configuration and select the corresponding device type. The device type corresponds to the first five digits of the arrangement number, which you can find on a label on your device.

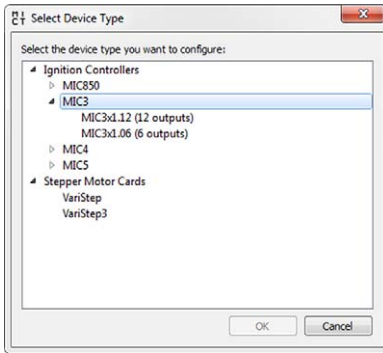

Click on the symbol to open a saved configuration.

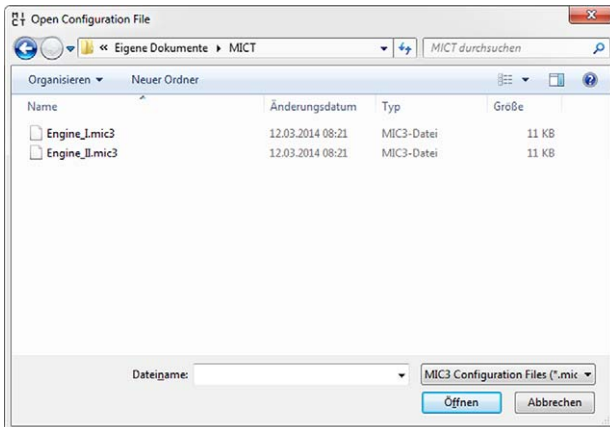

Click on the symbol to save the configuration currently displayed in the MICT to a data carrier.

8.10.2 Upload, Download



Click on the symbol to upload the current configuration from the MIC₃ to the MICT. The MICT first establishes a connection to the connected MIC₃ if necessary.



Click on the symbol to download the configuration set in the MICT to the MIC₃. This function can only be executed while the ignition is not active. This action overwrites the existing MICT configuration. The MICT first establishes a connection to the connected MIC₃ if necessary.



Existing configuration is cleared!

If you download a configuration to a MIC₃, the previous configuration is deleted and the new settings are immediately implemented.



Runtime adjustments

If you change a configuration stored in the MIC₃ via runtime adjustments, the configuration must be re-uploaded from the device so that the changes are displayed in the MICT's configuration views.

8.10.3 Compatibility Information

The following situations can arise if you upload a configuration from the MIC₃ to the MICT that does not correspond to the status of your MICT or if you open this type of configuration in the MICT:

- No values are present in the configuration for certain MICT functions. The MICT assumes the standard values for these functions.
- The configuration contains function values that are not support by the MICT.

The following situations can arise if you download a configuration from the MICT to a MIC₃ whose firmware does not correspond to the status of your MICT:

- No values are present in the configuration for certain firmware functions. The firmware continues to use the preset values for these functions.
- The configuration contains function values that are not support by the firmware.

If you download a configuration into the MIC₃ and are notified of functions that are not supported by the MICT, you should check the MIC₃ settings. Re-upload the configuration from the MIC₃ to the MICT. You can then see which settings are not transmitted to the MICT.

8 SETTINGS VIA THE MICT

Perform a firmware update, if necessary, and/or update your MICT so that you can use all the MIC3 functions without restriction.

8.11 Configuration

The window opens after you select the device type for a new configuration or an existing configuration or have uploaded one from the ignition controller. You can make changes to the configuration by selecting an entry from the navigation bar. The corresponding configuration data are then displayed in the configuration section and can be processed. The following sections will describe the settings and adjustments you can implement in the different areas.

8.11.1 Engine – Parameters

The screenshot shows the MICT configuration software interface. The window title is "unnamed.mic3* (MIC3x1.12) - MICT". The menu bar includes File, Device, Settings, Document, Tools, and Help. The left sidebar shows a Configuration Page tree with categories: Engine (Parameters, Cylinder Names, Ignition Outputs, Ignition Coils, Pickups), Timing (Analog Inputs, Schedule A, Schedule B), Inputs/Outputs (Alarms, ASO1, Inputs), and Miscellaneous (Communication, Information). The main area is titled "Parameters" and contains an "Engine Selection" table and an "Engine Information" panel.

Engine Manufacturer	Series	Type
AVAX	E08 Series	E2842E302
Caterpillar	E28 Series	E2842E312
Clark	E32 Series	E2842LE302
Cooper Bessemer		E2842LE312
EM		E2842LE322
Guascor		E2848LE322
Ingersoll Rand		E2876E302
Jenbacher		E2876E312
Liebherr		E2876LE202
MAN		E2876LE302
Wordberg		E2876TE302
Ruston		
Sequence		
Superior		
Waukesha		

Engine Information

Selected Engine Summary

MAN - E2842LE322

Engine Type: 12 cylinder 4-stroke V engine

Firing Angles

0.0
90.0
120.0
210.0
240.0
330.0
360.0
450.0
480.0
570.0
600.0
690.0
0.0

MOTORTECH does not assume liability for the information in the engine database. Please contact MOTORTECH if discrepancies are found.

If your engine is not available in the list contact MOTORTECH service please.

COM3 ID MIC3x1.12 (1.7.1 [0000ac01]) ADV. SERVICE Full Access Version: 1.28.2

Engine Selection

The MICT holds an engine database with data from various manufacturers and model series. Select the desired engine manufacturer, series, and type by clicking on the corresponding fields.

Wiring in firing order is assumed as standard. If straight order wiring is supported for the selected engine, the *Wiring* dialog opens and you have the opportunity to adapt the output configuration.

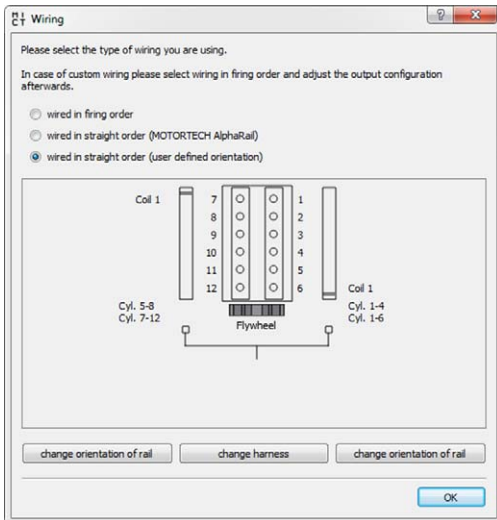

You can use straight order wiring, if:

- Wiring takes place via a corresponding MOTORTECH wiring harness and a MOTORTECH AlphaRail. The harness is marked with the following information: *CAUTION! The firing order needs to be configured directly in the ignition controller.* The ignition coils on the wiring rail are marked with *Connector Pin 1* to *Connector Pin X*. The position of coil1 on the wiring rail is marked in the *Wiring* view.
- Wiring of the ignition controller is done corresponding to the instructions in section *Straight Order Wiring of the Ignition Outputs* on page 36 (for example with an open wiring harness or via a junction box).

The configuration of the ignition outputs is automatically adapted corresponding to your selection. If you want to use a different wiring, these settings must be adapted appropriately.

If the pertinent engine is not available in the database, settings can also be entered by selecting the corresponding sequence. For this purpose, click on the entry *Sequence* in the column *Engine Manufacturer* and select the firing stroke in the column *Series*, then the number of cylinders, and the ignition offset of the engine as needed. After making your selections, the right hand section *Engine Information* will display a summary of the parameters selected.

8 SETTINGS VIA THE MICT

The summarized data are transferred to the subsequent configuration page *Ignition Outputs*. The values displayed there can only be changed by users with authorization to access the *Advanced Service* level.



Engine database

MOTORTECH does not assume liability for the information in the engine database. Please contact MOTORTECH if discrepancies are found.

New Engine Configuration

Staff with authorization for the *Advanced Service* level additionally have the option of entering the engine data manually, i.e. without selecting entries from the engine database. For this purpose, click on the *New Engine Configuration* button and select the engine type, number of cycles, and number of cylinders in the dialog box opening up. Additional information can be entered on the configuration page *Ignition Outputs*.

Dialog

Engine Type: V

Strokes: 4-stroke

Number of Cylinders: 8

Note: Specify Firing Order and Firing Angles on the Ignition Outputs Page!

OK Cancel

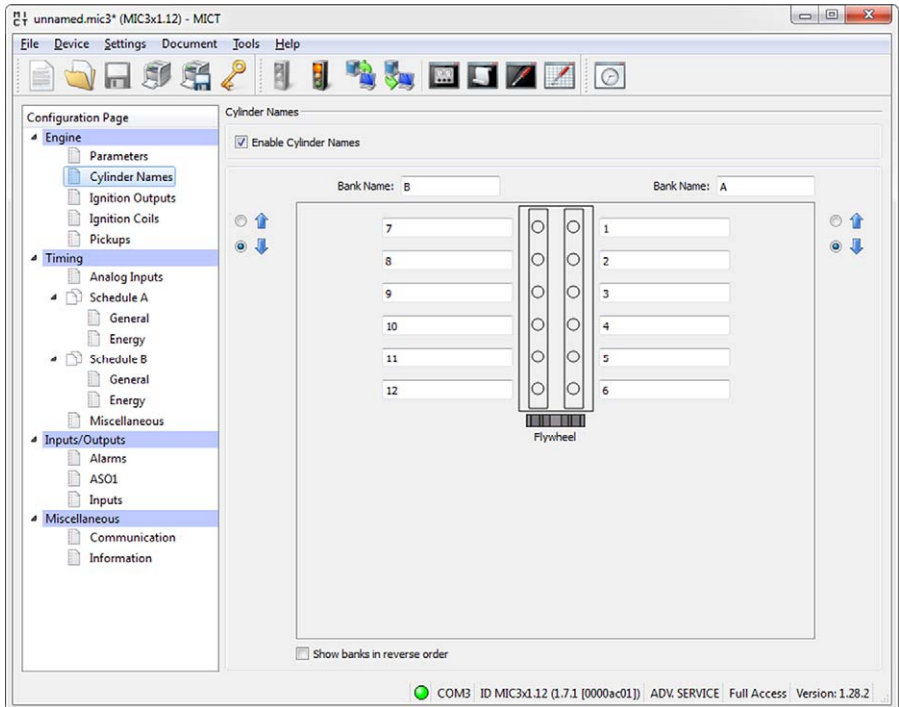

8.11.2 Engine – Cylinder Names



To facilitate the allocation of the cylinders during the configuration of the ignition outputs, you can individually name each cylinder. The schematic representation of the plan view of the selected engine supports you in this. Enter the following settings:

- **Enable Cylinder Names**
 Activate the checkbox in order to assign cylinder names. In order to use this function, the number of cylinders must be defined. Establish the number of cylinders either by using a configuration from the engine database or by creating a new engine configuration via the corresponding button. Refer to the section *Engine – Parameters* on page 64. If you have activated the checkbox, the assigned cylinder names must also be assigned to the corresponding ignition outputs, before the configuration is transferred to the ignition controller. Otherwise there will be an error message. Refer to the section *Engine – Ignition Outputs*.
- **Bank Name**
 Enter a name for the respective cylinder bank.
- **Cylinder Names**
 Enter a name for the respective cylinder.

8 SETTINGS VIA THE MICT

-   currently not used
- **Invert order of the banks for display** currently not used

8.1.1.3 Engine – Ignition Outputs

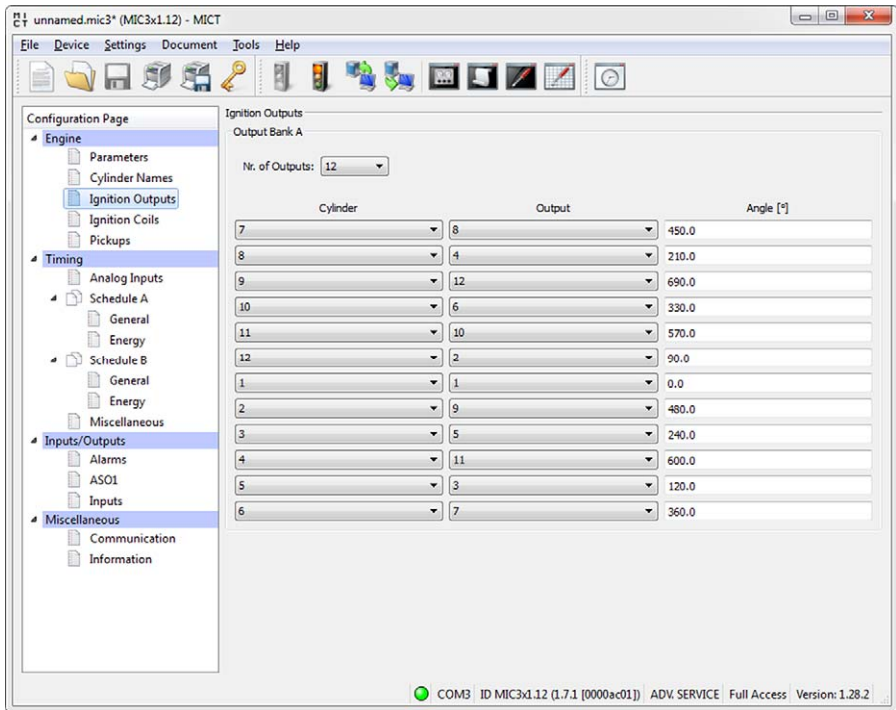

Configuration Page

- Engine
 - Parameters
 - Cylinder Names
 - Ignition Outputs**
 - Ignition Coils
 - Pickups
- Timing
 - Analog Inputs
 - Schedule A
 - General
 - Energy
 - Schedule B
 - General
 - Energy
 - Miscellaneous
- Inputs/Outputs
 - Alarms
 - ASO1
 - Inputs
- Miscellaneous
 - Communication
 - Information

Ignition Outputs

Output Bank A

Nr. of Outputs: 12

Cylinder	Output	Angle [°]
7	8	450.0
8	4	210.0
9	12	690.0
10	6	330.0
11	10	570.0
12	2	90.0
1	1	0.0
2	9	480.0
3	5	240.0
4	11	600.0
5	3	120.0
6	7	360.0

COM3 ID MIC3x1.12 (1.7.1 [0000ac01]) ADV. SERVICE Full Access Version: 1.28.2

Make adjustments to the following settings as needed:

- **Number of Outputs**
Select the number of outputs.
- **Column: Cylinder**
Select a cylinder. The displayed names are specified on the configuration page *Engine – Cylinder Names*.
- **Column: Output**
Select the number of the respective output.

- Column: **Angle**
Enter the firing angle for each output.

Default Application

If you select from the engine database, the data stored for the selected configuration are displayed. These data can only be changed by personnel with access to the *Advanced Service* level.

New Engine Configuration

Selecting the number of outputs enables access to the fields for the configuration of the outputs. By default, the ignition outputs are distributed so that cylinder 1 of the ignition sequence is always allocated an ignition angle of 0°. The ignition angle for each output results from the addition of the ignition spacing to the respective previous output.



Operational safety

Never connect more than one output to each ignition coil, as the output boards can otherwise be damaged!

The allocation of outputs to the device's output connector contacts and the cylinders is determined by the wiring. The user must take the wiring into account during the configuration; it cannot be checked by the software.



Interval between two ignitions

The interval between two ignitions must be min. 1.7 ms. During the check, the configured overspeed is used in the calculation.

8 SETTINGS VIA THE MICT

8.11.4 Engine – Ignition Coils

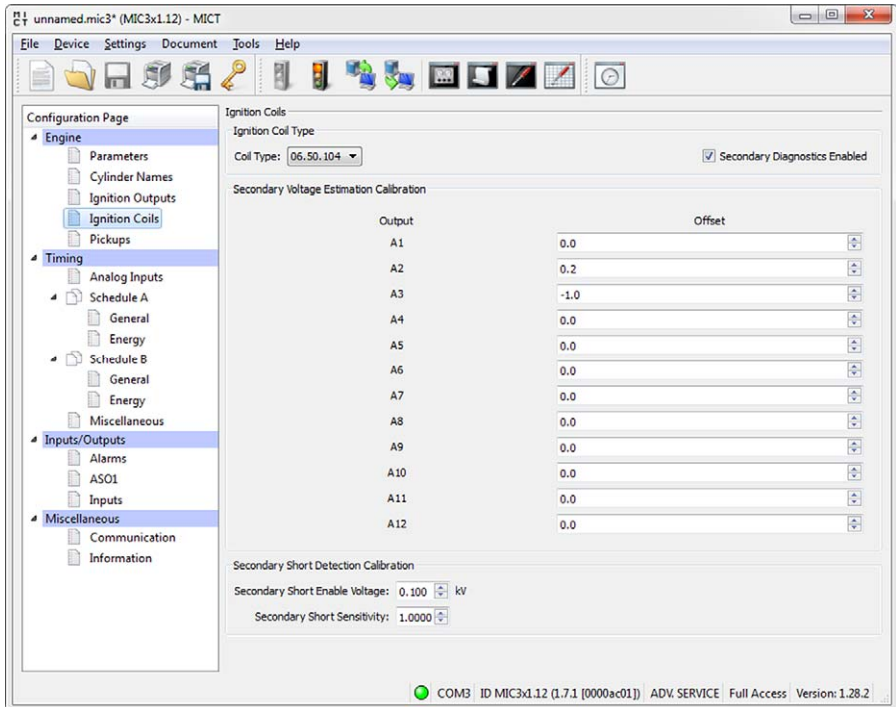

Ignition Coil Type

Select the ignition coil type from the drop-down list. (Without this selection the configuration cannot be downloaded to the MIC₃.)



Only use measured ignition coils

To operate the MIC₃, only ignition coil types measured by MOTORTECH may be used. All ignition coils used must correspond to the part number selected in the drop-down list. Different coil types must not be mixed and also no equivalent or replacement types may be used.

If a coil type used is not in the drop-down list, then the MIC₃ is currently not used.

Secondary Diagnosis

The secondary diagnosis can be deactivated and activated for ignition coils that support this function. If the ignition coil function is not supported, the calibration of the secondary voltage estimation and the calibration of the secondary short-circuit monitoring are not available.

Secondary Voltage Estimation Calibration

A correction value without units can be set for the secondary voltage estimation for every configured output to increase the accuracy of the secondary voltage estimation for each individual cylinder. E. g. this allows different cable lengths on the engine to be compensated.

The values of the secondary voltage estimation can be changed for each individual cylinder. The value range depends on the ignition coil. 0.0 is set as the standard value for all cylinders. You can adjust the secondary voltage estimation while the engine is running in the runtime adjustments (refer to *Runtime adjustments – Secondary Voltage Estimation Calibration* on page 117).

Secondary Short Detection Calibration

The starting voltage and the secondary short detection sensitivity can be adjusted. You can adjust the secondary short detection in the runtime adjustments while the engine is running (refer to *Runtime adjustments – Secondary Short Calibration* on page 118).

Secondary Short Enable Voltage:

Set the necessary average ignition voltage required to activate the secondary short-circuit monitoring:

- The secondary short detection is always activated at a value of 0 kV.
- The secondary short detection is always deactivated at a value of 65.535 kV.

Secondary Short Sensitivity:

The permitted value range depends on the set ignition coil.

E. g. set the sensitivity of the short-circuit detection as follows:

- The sensitivity is high at a value of 0.98.
- The sensitivity is low at a value of 1.02.

8 SETTINGS VIA THE MICT

8.11.5 Engine – Pickups

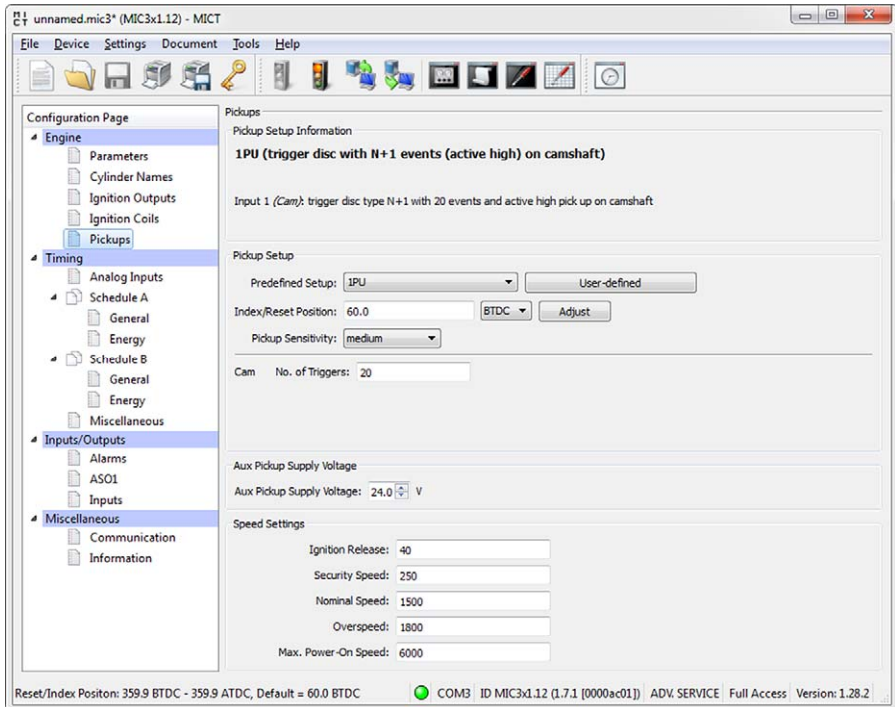

Active pickups

Check when using active pickups that the auxiliary supply voltage is configured for your application.

Pickup Setup Information

The settings made in the *Pickup Setup* section were summarized once again in the section *Pickup Setup Information*.

Pickup Setup

Enter the following settings in this section:

- **Predefined Setup**
Select the pickup configuration suitable for your application from the list. The configurations available for selection depend on the previously entered settings.
- **Index/Reset Position**
Enter the distance between the first event after the set index/ reset marking and top dead center. With the button *Adjust*, you can enter the measured firing angle for a given nominal value. The system calculates the difference from these values, which is added to or subtracted from the index/reset position.
- **Pickup Sensitivity**
Open the pick list and select the desired sensitivity level for the pickup from the list offered. This setting overwrites the value of the pre-trigger voltage if the latter was defined in the user-defined pickup set-up.
 - **High**
The signal processing starts at low engine speeds. This setting can result in increased susceptibility to failure.
 - **Medium**
Standard setting of the MICT. This is a trade-off between start-up speed and sensitivity.
 - **Low**
The signal processing does not start until high engine speeds are reached. This setting can result in reduced susceptibility to failure.
- **Trigger/Cam Teeth Number**
Enter the number of events. The input *Cam* or *Trigger* is automatically selected by the MICT and is governed by the selection of the pre-defined pickup settings.
- **User-defined**
Staff authorized to access the *Advanced Service* level can, in addition to the standard settings access, use a manual setup option by clicking on the *User-defined* button.

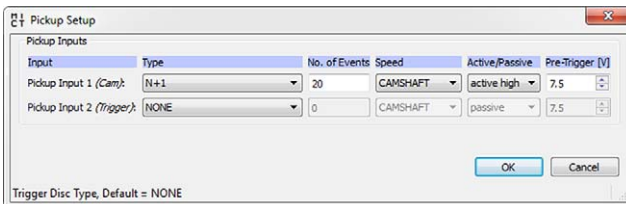

Input	Type	No. of Events	Speed	Active/Passive	Pre-Trigger [V]
Pickup Input 1 (Cam)	N+1	20	CAMSHAFT	active high	7.5
Pickup Input 2 (Trigger)	NONE	0	CAMSHAFT	passive	7.5

Trigger Disc Type, Default = NONE

8 SETTINGS VIA THE MICT

- **Type**

Select the type of events that will occur on the respective input for each pickup input. Type and number of events are defined by the discs or ring gears used. If you decide not to use a pickup input, select the entry *not used* from the list. You can set the following types:

- N**

Disk, which causes a uniformly distributed number (N) of events (per rotation), e.g. a ring gear with 160 teeth (N=160).

- N+1**

Disk type N with one additional event, e.g. a disk with 12 teeth and one additional tooth for the index signal (N=12).

- N+1 expanded index range**

Disk type N with an additional event, e.g. with one additional disk with 12 teeth and one additional tooth for the index signal (N=12). The permitted range for the index signal is expanded to 75 % of the tooth period. An incorrect direction of rotation of the engine cannot be detected by this setting.

- N-1**

Disk type N, where one event is missing, e.g. a ring gear with 160 teeth on which one tooth was removed (N=160). This missing event is used to determine the index signal

- N-2**

Disk type N, where two consecutive events are missing, e.g. a ring gear with 60 teeth on which two teeth located next to each other were removed (N=60). This missing event is used to determine the index signal.

- N Magnets, Individual Magnet**

You will always use these two types together for a disk with magnets having opposite polarity. A magnet with a fixed number of magnets (N), all of which are arranged at equal distances on the disk, has a reverse polarity. Thus, the disk supplies two signals that can be analyzed by a pickup.

- Single Event**

Disk that supplies a single event, e.g., a disc with one tooth or one magnet.

- **Number of Events**

Enter the number of events that occur on the pickup if more than one event is expected. For the types *N+1* and *N-1*, enter the value for N and not the total number of events. With the type *N Magnets*, the number of magnets with identical polarity must be entered. The number of events must lie between 3 and 500. Additionally, it must be ensured that the sum of the frequencies at the pickup input does not exceed the limit of 10 kHz at the pre-set overspeed.

- **Speed**

Select whether the respective pickup will pick up the signal off the camshaft or the crankshaft.

- **Active/Passive**
 Select the pickup to be used from the pre-defined pick list:
Passive
 passive pickup
Active (low)
 active pickup with High level as quiescent level
Active (high)
 active pickup with Low level as quiescent level
- **Pre-Trigger**
 Enter a value between 0.1 V and 7.5 V for every pickup in order to set the pickup sensitivity. Signals that fall short of the set voltage will not be analyzed. A low pre-set value therefore results in a high sensitivity level, a high value results in a low sensitivity level.



Pickup setup information

The respective latest setting in the area of the pre-defined or arbitrary pickup settings is transferred to and displayed under *Pickup Setup Information*.

Aux. Pickup Supply Voltage

Enter the supply voltage with which the active pickup is to be operated. A value between 5 and 24 V is possible.

Speed Settings

Enter the following settings in this section:

- **Ignition Release**
 Enter the release speed for the ignition at which the first ignition is to fire. The value shall not exceed 1/7 of the nominal speed.
- **Security Speed**
 Enter the security speed (max. half the nominal speed). Below the value entered, the ignition can be switched on and off as desired. If the ignition is deactivated during operation above the set speed, the ignition cannot be immediately reactivated. Only when the ignition no longer reads a speed, i.e., the engine has come to a standstill, can the ignition be reactivated.
- **Nominal Speed**
 Enter the nominal speed at which your engine is to be operated. With engines that are to be operated with variable speeds, the max. speed of the operating range must be entered.

8 SETTINGS VIA THE MICT

– Overspeed

Enter the speed at which the ignition is to be shut off as overspeed protection. With engines that are to be operated with variable speeds, a speed above the operating range must be entered.

– Max. Power-on Speed

Enter the maximum permitted start speed at which the MIC₃ starts sending ignition pulses. A value of *6000 rpm* is set as the default value: The MIC₃ can be activated at the starter speed and immediately send ignition pulses.

For a value of *0 rpm* the MIC₃ can only start sending ignition pulses once it has registered that the engine is at a standstill.

8.11.6 Timing – Analog Inputs

The screenshot shows the MICT software interface for configuring an engine. The window title is "unnamed.mic3* (MIC3x1.12) - MICT". The menu bar includes File, Device, Settings, Document, Tools, and Help. The left sidebar shows a tree view with the following structure:

- Configuration Page
 - Engine
 - Parameters
 - Cylinder Names
 - Ignition Outputs
 - Ignition Coils
 - Pickups
 - Timing
 - Analog Inputs (selected)
 - Schedule A
 - General
 - Energy
 - Schedule B
 - General
 - Energy
 - Miscellaneous
 - Inputs/Outputs
 - Alarms
 - ASO1
 - Inputs
 - Miscellaneous
 - Communication
 - Information

The main area displays "Analog Inputs Base Settings" with the following fields:

- Analog Current Input
 - Lower Limit: 4.0 mA
 - Upper Limit: 20.0 mA
 - Failure Threshold: 3.2 mA
- Analog Voltage Input
 - Lower Limit: 0.0 V
 - Upper Limit: 5.0 V
 - Failure Threshold: 0.0 V
- Aux Analog Input Supply Voltage
 - Aux Analog Input Supply Voltage: 24.0 V

The status bar at the bottom shows: "Reset/Index Position: 359.9 BTDC - 359.9 ATDC, Default = 60.0 BTDC" and "COM3 ID MIC3x1.12 (1.7.1 [0000ac01]) ADV. SERVICE Full Access Version: 1.28.2".



Auxiliary supply voltage

Check with the configuration of the analog inputs, that the set auxiliary supply voltage corresponds to your application.

Analog Inputs Base Settings

The timing adjustment can be made using two analog input signals, which can be set within the following limits:

- Analog Current Input: 0-20 mA
- Analog Voltage Input: 0-10 V

Set the *Upper Limit* and *Lower Limit* of the signals corresponding to your connected device. Also, you have the option to enter a *Failure Threshold*. If the signal does not reach this value, it is classified by the ignition controller as failure (e. g. wire break).

You set the analog input that will be used and which timing adjustment results from the analog signal for the two possible schedules. Refer to the section *Timing – Schedule A/B – General* on page 78.

Aux. Analog Input Supply Voltage

An auxiliary supply voltage can be configured for the analog inputs. Enter a voltage value between 5 and 24 V.

8 SETTINGS VIA THE MICT

8.11.7 Timing – Schedule A/B – General

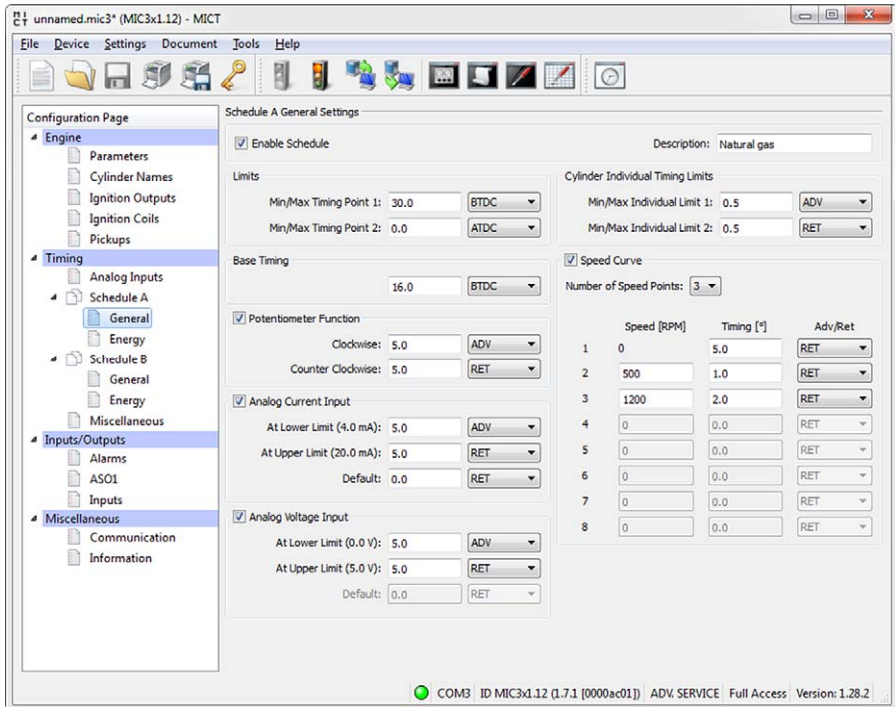

Schedule A General Settings

The MIC3 offers two schedules for implementing the necessary settings for the timing of the engine. The schedules A and B can be used for dual fuel operation, for example. The system switches between the schedules via the input *Schedule A/B*. If only one schedule is configured the switch is ignored. The configuration options for schedule B are identical to those for set A.

– Enable Schedule

The settings are enabled or disabled by checking/unchecking the box. One schedule must always be activated.

– Description

Enter a description for the schedule (e. g. *natural gas* for the setting for this type of gas).

Ignition Timing Limits

Enter the limits of the timing point at which the ignition can fire. The timing points of the outputs will be limited to this range relative to the respective top dead center of the pertinent cylinder. The global timing can then not be shifted beyond this range by any adjustments.

Base Timing

Enter the timing specified by the engine manufacturer. This point must be within the limits entered and is a static portion of the global timing.

Analog Inputs

The analog inputs can be enabled and disabled by clicking. If you have the choice, you should prefer the analog current input due to its lower sensitivity to faults.

Enter the values by which the adjustment is to be implemented for the corresponding input signal. A *Default* can be entered for the signals, if a *Failure Threshold* is defined in the window *Timing – Analog Inputs* for the respective entry. If the signal is below the Failure Threshold, the timing is offset by the error value. The offset remains until the signal again exceeds the lower set limit.

Cylinder Individual Timing Limits

Enter the maximum possible cylinder individual offset. This setting limits, among other things, the adjustment possibility in the window *Cylinder Individual Offset*. In addition the limits also apply to the corresponding adjustment signals from all other sources, for example via the field buses.

Speed Curve

The speed curve can be activated and disabled by mouse click and offsets the timing depending on the speed. A max. of eight speed points are available. If you select a number of points from the list, the corresponding number of fields is activated for input.

The first speed point is always set to 0 RPM. All other timing points are assigned with the value by which the signal is to be offset when the respective speed is reached. For the last speed point, the timing of the nominal speed should be entered. Please note that the speed points must always be entered in ascending order.

8 SETTINGS VIA THE MICT

8.11.8 Timing – Schedule A/B – Energy

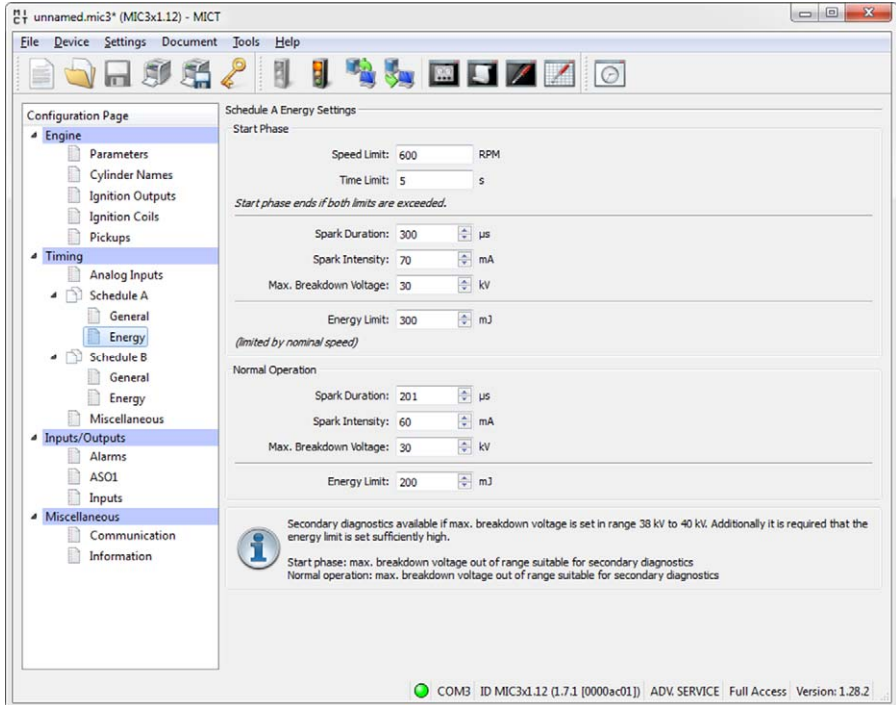

You can make different energy settings for the start phase and normal operation.

Start Phase

Set the start phase of your engine. To do this you can enter a *Speed Limit*, a *Time Limit* or both. If you enter values for both criteria, both values must also be exceeded, so that the ignition controller classifies the start phase as ended and sets the values for normal operation. If you only want to use one criterion, set the other values to 0. If you do not want to set a start phase, set the two values to 0.

Enter values specific to your application for the *Spark Duration*, the *Spark Intensity* and the *Maximum Breakdown Voltage*. The maximum breakdown voltage corresponds to the maximum voltage expected during operation.

Normal Operation

If the criteria specified for the start phase are exceeded, the settings for normal operation are used by the ignition controller. Make the energy settings the same as for the start phase.

Energy Limit

You can use the *Energy Limit* field to limit the output energy made available by the ignition controller. If the set output energy is no longer sufficient to reach the set energy values (spark duration, spark intensity, max. breakdown voltage), the spark duration is reduced correspondingly.



Required supply voltage for energy control

Depending on the output configuration and the energy settings, for a correct energy control, a higher supply voltage than the minimum 10 V DC sufficient for operation of the device can be necessary. If this is the case, the required supply voltage is displayed in a notice in the window *Timing – Schedule A/B – Energy*.

8.11.9 Timing – Miscellaneous

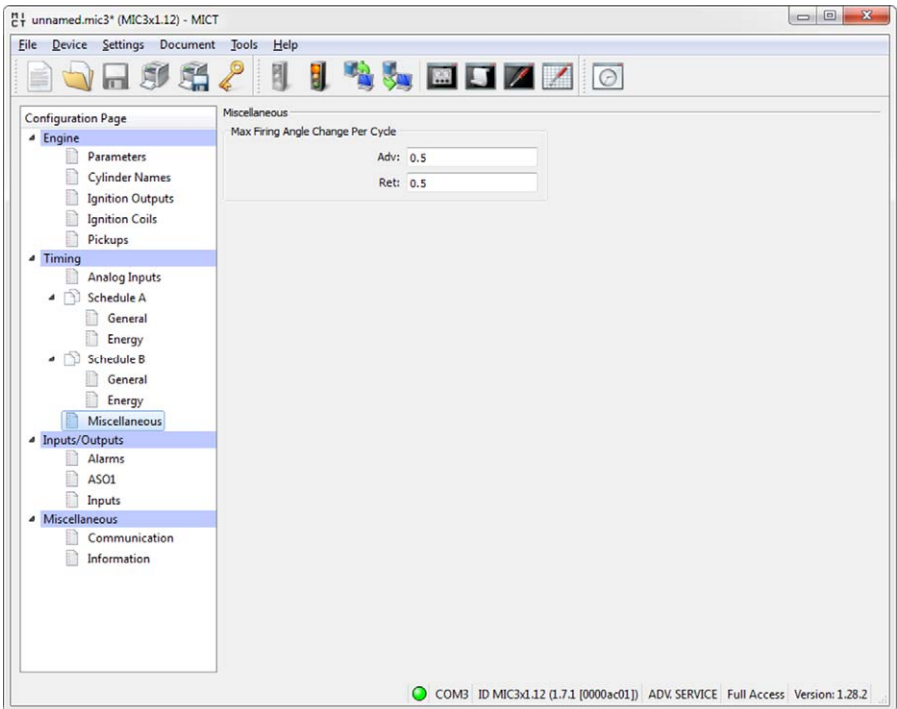

You can specify how fast the changes of the timing should be executed.

8 SETTINGS VIA THE MICT

– Maximum Firing Angle Change Per Cycle

Specify the maximum degrees per cycle that the ignition timing may be shifted by for both directions, i. e. between two firings of a cylinder. If the specified ignition timing shift is larger than the given value, it is divided among several cycles.

8.11.10 Inputs/Outputs – Alarms

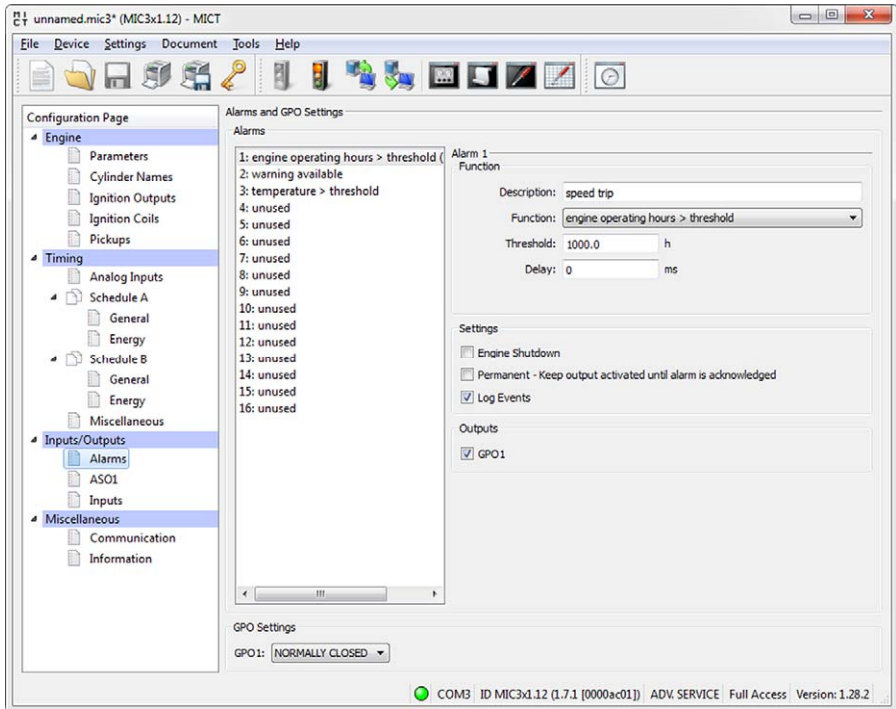

The MIC3 ignition controllers include a total of 16 configurable alarms that can be allocated to the general purpose output.

– Description

You can enter any desired description for an alarm. The description is used for logging the alarms that have occurred in the event list in the MICT.

– Function

The alarms can be used depending on the following functions:

- unused
- Speed above threshold / below threshold
- Engine operating hours above threshold / below threshold

- Spark plug operating hours above threshold / below threshold
- Warning active
- Error active
- Temperature above threshold / below threshold
- analog voltage input over threshold / under threshold
- analog current input over threshold / under threshold
- Global ignition timing above the threshold / below the threshold
- Supply voltage above threshold / below threshold
- Min. spark duration above threshold / below threshold
- Misfire rate (primary, single output) over limit
- Misfire rate (primary, all outputs) over limit
- Misfires per second (primary, all outputs) over limit
- Consecutive misfires (primary, single output) over the threshold
- Misfire rate (secondary, single output) over limit
- Misfire rate (secondary, all outputs) over limit
- Misfires per second (secondary, all outputs) over limit
- Consecutive misfires (secondary, single output) over the limit
- **Threshold**
Input of desired threshold value.
- **Hysteresis**
Input of desired hysteresis value.
- **Delay**
Input of desired delay. The threshold value defined in the alarm must have been exceeded or not reached for a longer period than the specified time for an alarm to be triggered. If a corresponding value occurs for a shorter period of time, no alarm is triggered.
- **Engine Shutdown**
If this checkbox is checked, the ignition is switched off as soon as the alarm is triggered.
- **Permanent – Keep output activated until alarm is acknowledged**
If this box is checked, the output remains permanently active until the alarm is acknowledged. If the box is not checked, the output remains active only for as long as the alarm is active.
- **Log Events**
If this box is checked, the event list records when the alarm occurred or when it was acknowledged.
- **Outputs**
Activate the checkbox *GPO1*, so that the general purpose output is activated when the alarm is triggered.

8 SETTINGS VIA THE MICT

– GPO 1

Configure the general purpose output as Normally closed or Normally open.

8.11.11 Inputs/Outputs – ASO₁ (auxiliary synchronization output)

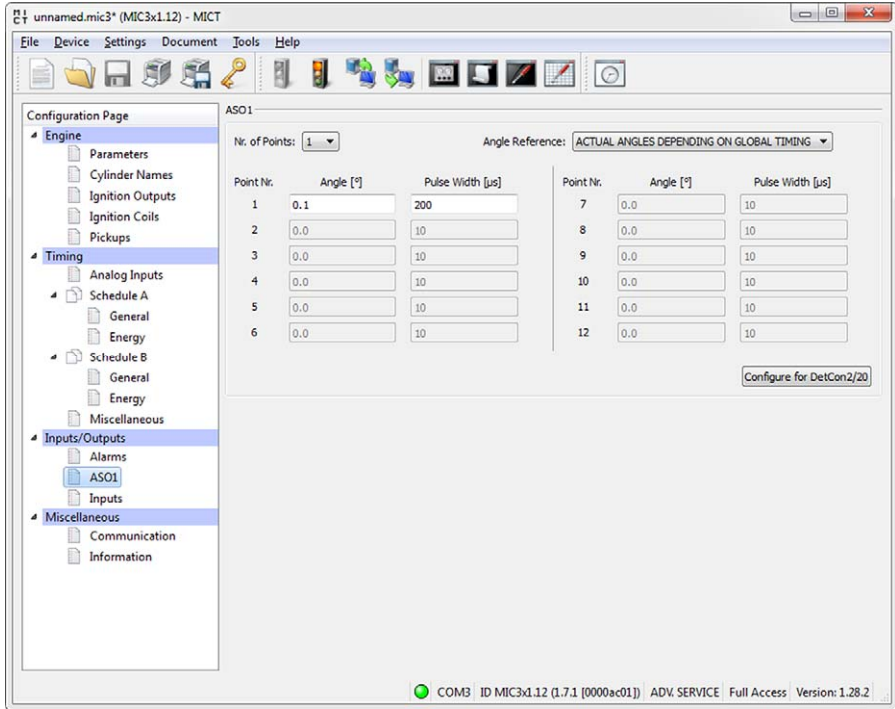

With the auxiliary synchronization output, freely definable impulses depending on the angle of the crankshaft can be generated. For the output, the user defines whether the angle will be absolute or based on the global timing. The output can generate between 1 and 12 impulses and only be assigned to one system at a time. One example of the application of the ASO output for a detonation controller can be found in section *ASO: Auxiliary Synchronization Output* on page 45.

– No. of Points

Select the number of impulses from the *No. of Points* list. Please note that the DetCon detonation controller devices require a single impulse with 200 µs synchronous with the first cylinder in the ignition sequence. You can get this setting via the button *Configure for DetCon2/20*.

– **Angle Reference**

Select from the *Angle Reference* drop-down list whether the angle shall be based on the absolute angle of the crankshaft or the actual angle depending on global timing. Then, enter the trigger angle for each impulse and the length of the impulse in μs .



Maximum impulse duration

Please note that the duration of the impulse can be entered as max. 300 μs . Input of higher values will not be accepted by the system.

8.11.12 Inputs/Outputs – Inputs

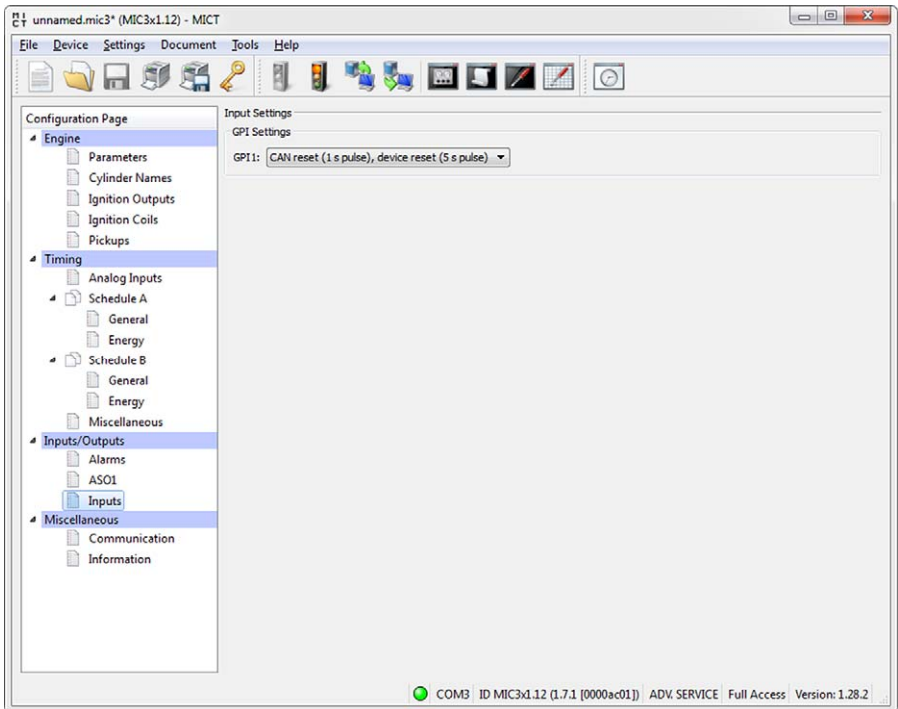

The multi-purpose input GPI1 can be used to perform a CAN-reset or a device-reset externally (e. g. by a master control). A high pulse of 1 second results in a reset of the CAN-driver and a high pulse of 5 seconds results in a device-reset.

8 SETTINGS VIA THE MICT

You can activate and disable the GPI1 using the drop-down list.

8.11.13 Miscellaneous – Communication

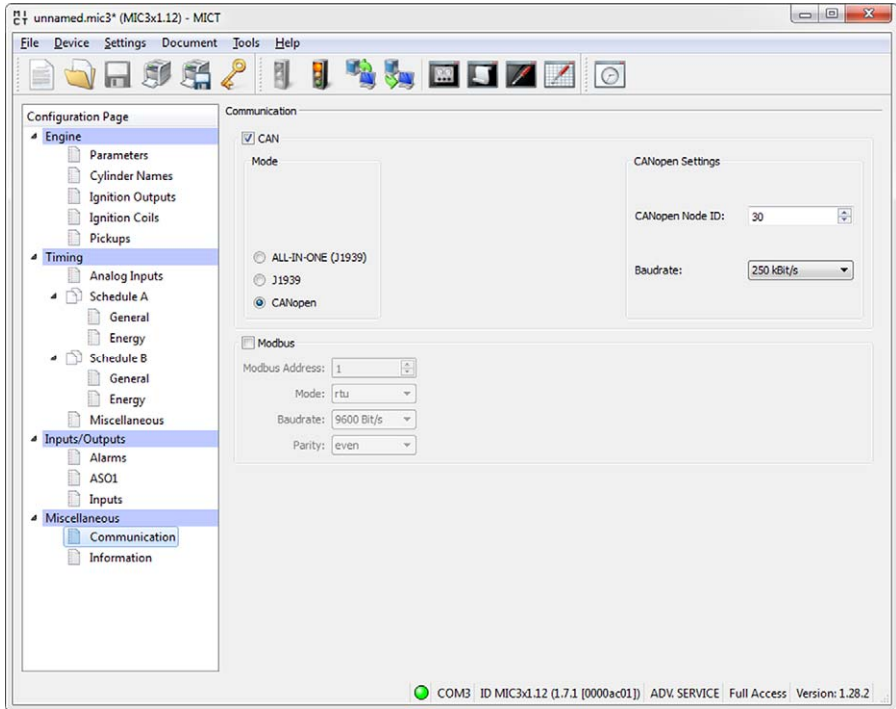

CAN

Clicking on the *CAN* checkbox enables or disables the CAN interface on the device.

– ALL-IN-ONE (J1939)/CANopen

Please select the desired protocol, depending on whether you want to set the communication for the ALL-IN-ONE or for another device. For example, for a connection to the PowerView3, select CANopen.

– J1939

The J1939 source address can be assigned between 0 and 253. Please note that IDs cannot be assigned more than once.

– CANopen node ID

The CANopen node ID can be assigned between 1 and 127. Please note that IDs cannot be assigned more than once.

- **Baud rate**
Select the desired data transfer rate from the list. The baud rate can be defined between 50 kBit/s and 1 MBit/s, the recommended value being 250 kBit/s.

Modbus

Clicking on the *Modbus* field enables or disables the Modbus interface on the device.

- **Modbus Address**
The Modbus address can be between 1 and 247. Please note that IDs cannot be assigned more than once.
- **Modbus**
Please define if the data are transferred in the ASCII or RTU mode.
- **Baud rate**
Select the desired data transfer rate from the list. The Modbus baud rate can be defined between 9600 and 115200 bit/s, the recommended value being 19200 bit/s.
- **Parity**
Please define if a parity bit is used and if the parity is to be even or uneven. If no parity is selected, then two stop bits are sent according to Modbus specification, otherwise one stop bit is sent.



Setting the transfer rate

Please note that all devices connected with a bus must be set to the same transfer rate.



Information on logs

Please contact your MOTORTECH contact partner if you require more information on the CANopen, J1939 and Modbus logs.

8 SETTINGS VIA THE MICT

8.11.14 Miscellaneous – Information

This configuration page can be viewed by all users, but changes can only be made with authorization for the *Service* access level.

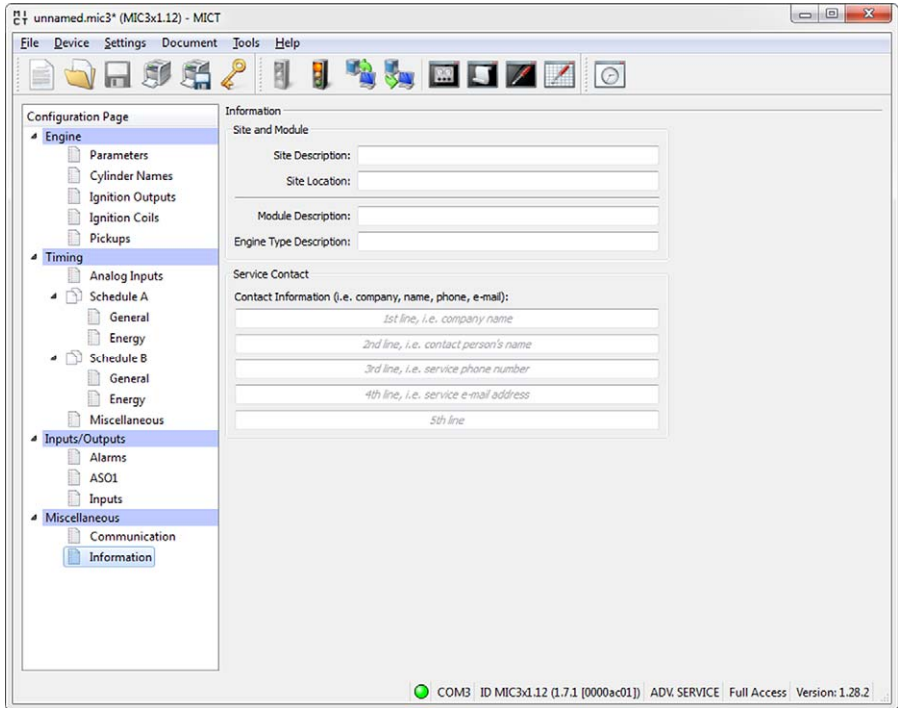

Site and Module

In this section, enter information on the system and the module for which the configuration will be used.

Service Contact







In this section, individual contact data can be saved that can be called up and displayed via MICT.

8.12 Runtime Data



Click on the symbol to open the window *Runtime Data*. The following sections will give you an overview of the data you can view on the individual tabs.

You can print and record the runtime data. For this purpose, the following functions are at your disposal in the toolbar in the window:

Symbol	Function
	Prints the runtime data.
	Prints the runtime data to a PDF file.
	Opens the print preview.
	Starts the runtime data trace.
	Stops the runtime data trace.
	Acknowledges the operating errors. If an operating error is acknowledged, all alarms are also simultaneously acknowledged. The symbol is grayed out if no acknowledged error is present.

8 SETTINGS VIA THE MICT

8.12.1 Runtime Data – Overview

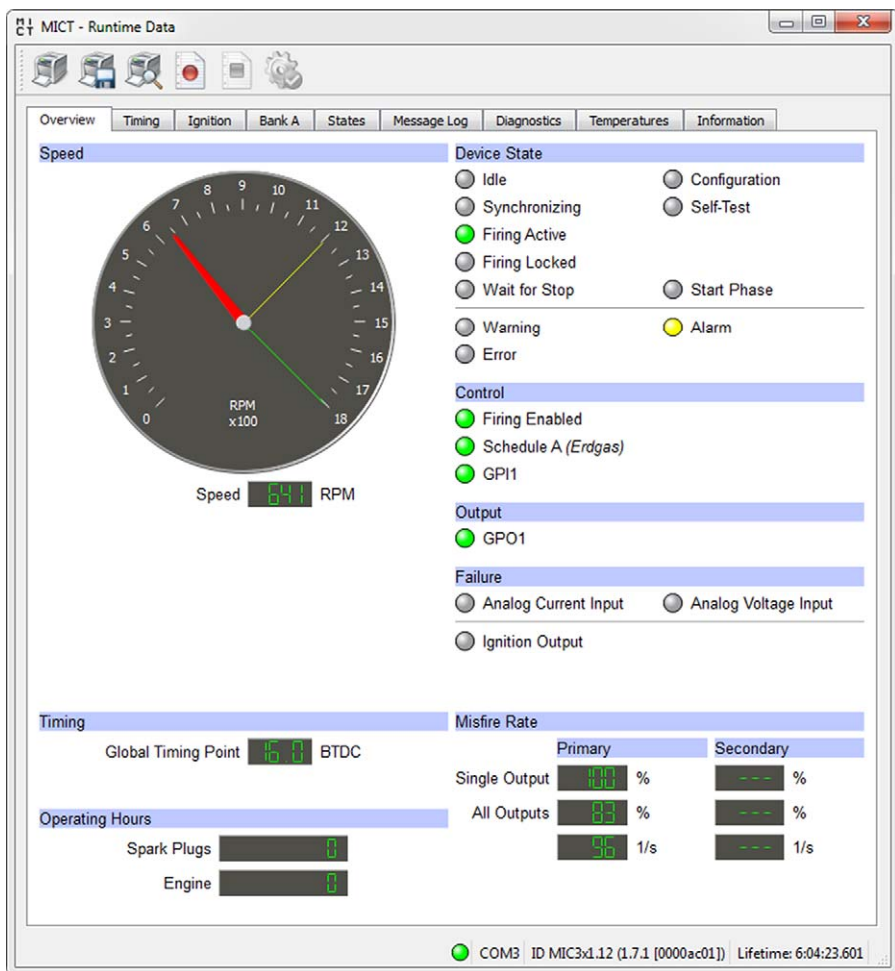

In this screen, you can find the following information:

- **Speed Indicator (analog)**
 - Red Pointer
Displays the current registered speed
 - Yellow Pointer
Displays the maximum registered speed since last starting the engine

- Green Pointer
Display of set overspeed
- **Speed Indicator (digital)**
Digitally displays the current speed
- **Global Timing Point**
Digital indication of the current global timing
- **Operating Hours**
 - **Spark Plugs**
Indicates the current operating hours of the spark plugs
 - **Engine**
Indication of current operating hours of the engine
- **Device State**
The status of the device is shown by the following status displays:

Device status	Description
Idle	The ignition is ready and waiting for pickup activity.
Synchronizing	Pickup signals are being received and analyzed.
Firing Active	The ignition is active.
Firing Locked	Pickup signals are being received and are valid, ignition is not released.
Wait for Stop	Pickup signals are being received, the ignition fired above the security speed, and the ignition release was retracted. The engine must now come to a standstill.
Configuration	The device is being configured.
Self Test	The self test is running (refer to <i>Self Test</i> on page 56).
Start Phase	The engine is in the configured start phase (refer to <i>Timing – Schedule A/B – Energy</i> on page 80).
Warning	A warning occurred (refer to <i>Warnings</i> on page 104).
Error	An error occurred (refer to <i>Errors</i> on page 104).
Alarm	A configured alarm occurred (refer to <i>Alarms</i> on page 104).

- **Control**
 - **Firing Enabled**
The green status display signals that the firing is active.
 - **Schedule A/B**
The green status display shows which parameter settings are currently used.

8 SETTINGS VIA THE MICT

- **GPI₁**
The status indicator shows the status of the input signal.
- **Output**
 - **GPO₁**
The general purpose output is switched on with the green status display.
- **Failure**
 - **Analog Current Input**
The red status display signals that the set failure threshold for the input has been reached. If the lower limit of the signal is reached again, the status display is again gray.
 - **Analog Voltage Input**
The red status display signals that the set failure threshold for the input has been reached. If the lower limit of the signal is reached again, the status display is again gray.
 - **Ignition Output**
The red status display signals a current misfire on at least one output. With a yellow status display at least one misfire has occurred at one output since the last reset of the counter.
- **Misfire Rate**
The misfire rate is displayed for the primary side and the secondary side. The misfire rate on the secondary side is only displayed if the secondary side diagnosis is activated (refer to *Engine – Ignition Coils* on page 70).
 - **Single Output**
Displays the misfire rate of the output for which the most misfires were registered during the last 32 cycles.
 - **All Outputs**
Displays the misfire rate for all the ignition outputs for the past 32 cycles.
 - The number of misfires per second are calculated by the MIC₃ as follows:
2-stroke engine: $\text{Number of currently misfiring outputs} \times \text{RPM} / 60$
4-stroke engine: $\text{Number of currently misfiring outputs} \times \text{RPM} / 60 / 2$

8.12.2 Runtime Data – Timing

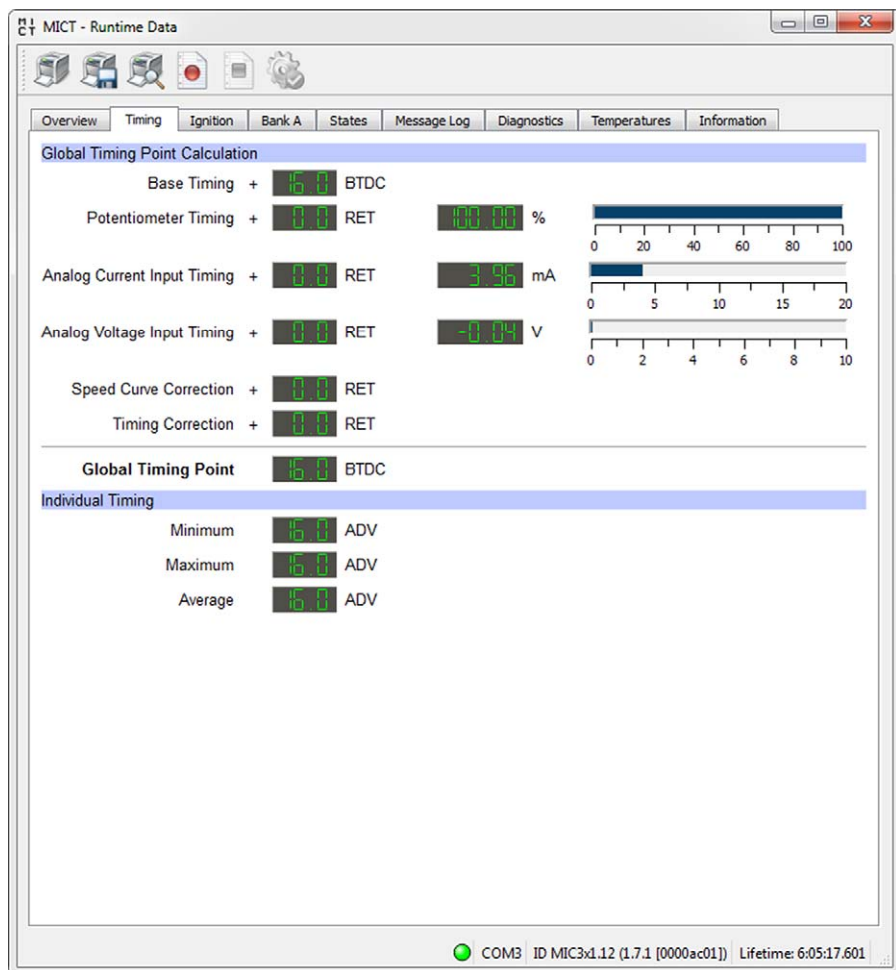

In this view, the system displays all values and settings in the left hand section that influence the ignition timing. In the right hand section, values are additionally displayed and shown as a bar chart that are measured at the three inputs (potentiometer, analog current and voltage input) and thus cause the changes to the timing shown. The value for the speed curve results from the curve progression set in the configuration. Refer to the section *Timing – Schedule A/B – General* on page 78. The timing correction can be implemented for the runtime. Please refer to the section *Runtime Adjustments – Timing* on page 114.

8 SETTINGS VIA THE MICT

In the lower range, the maximum, minimum and average of the cylinder individual offsets are also displayed.

8.12.3 Runtime Data – Ignition

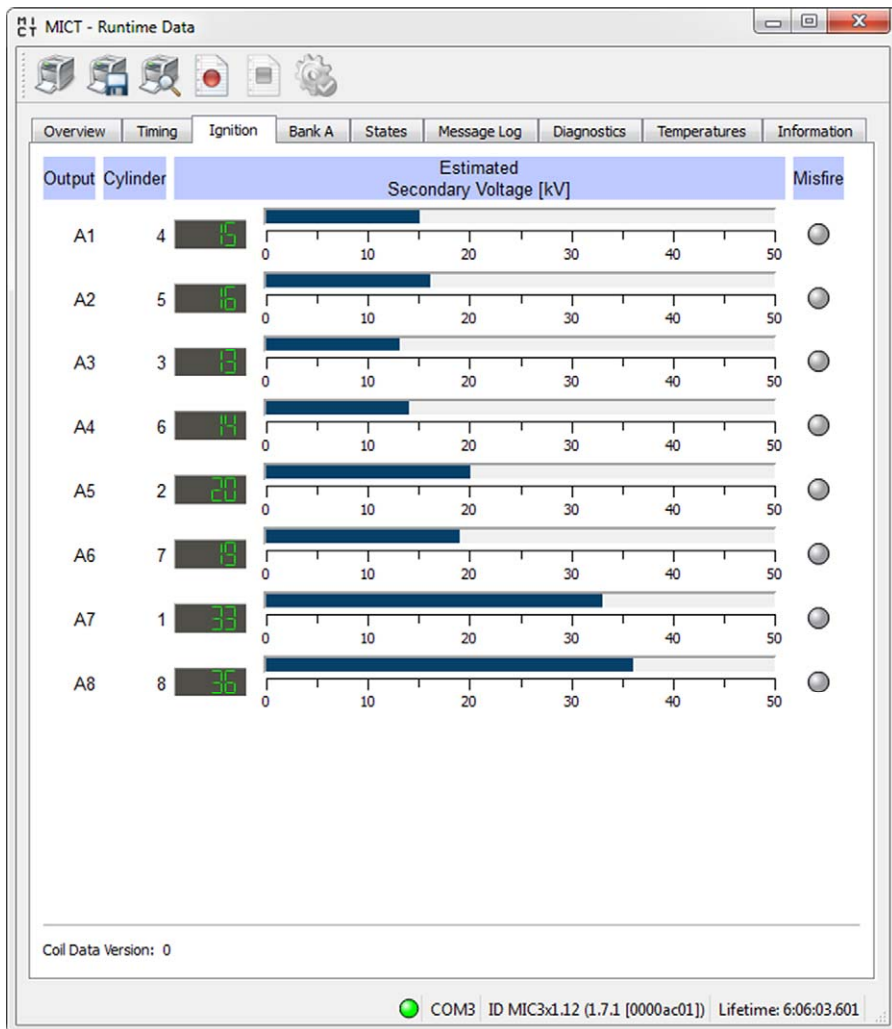

The following information is provided:

- Column: **Output**
Designation of the output
- Column: **Cylinder**
If cylinder names have been assigned, these are displayed
- Column: **Estimated Secondary Voltage [kV]**
Secondary voltage determined by the ignition controller of the respective output.
The secondary voltage estimate is used to determine deviations between the individual outputs. These indicate a possible problem at this output (e. g. problems in the area of the spark plug or the cylinder).
If you have set the ignition coils (refer to *Engine – Ignition Coils* on page 70) for which a secondary voltage estimate does not seem possible "---" appears.
- Column: **Misfire**
The red status display signals a current misfire at the respective output. With a yellow status display at least one misfire has occurred at the respective output since the last reset of the counter.

The coil data version configured in the MIC3 is displayed under the ignition runtime data.

8 SETTINGS VIA THE MICT

8.12.4 Runtime Data – Bank A

The screenshot shows the 'MICT - Runtime Data' application window. The 'Bank A' tab is selected, displaying a table of engine data for 12 cylinders (A1 to A12). The table includes columns for Output, Cylinder, Angle, Min. Spark Duration, Energy Output, and Misfire (Primary and Secondary) with open/short indicators and Rate [%].

Output	Cylinder	Angle [° Crank]	Min. Spark Duration [µs]	Energy Output [mJ]	Misfire					
					Primary			Secondary		
					open	short	Rate [%]	open	short	Rate [%]
A1	1	16.0 ADV	201.0	159	●	●	0	○	○	---
A2	12	16.0 ADV	201.0	311	●	●	0	○	○	---
A3	5	16.0 ADV	201.0	55	●	●	0	○	○	---
A4	8	16.0 ADV	201.0	56	●	●	0	○	○	---
A5	3	16.0 ADV	201.0	56	●	●	0	○	○	---
A6	10	16.0 ADV	201.0	56	●	●	0	○	○	---
A7	6	16.0 ADV	201.0	57	●	●	0	○	○	---
A8	7	16.0 ADV	201.0	57	●	●	0	○	○	---
A9	2	16.0 ADV	201.0	56	●	●	0	○	○	---
A10	11	16.0 ADV	201.0	55	●	●	0	○	○	---
A11	4	16.0 ADV	201.0	57	●	●	0	○	○	---
A12	9	16.0 ADV	201.0	56	●	●	0	○	○	---

Show Firing Angles: Relative Absolute

COM3 ID MIC3x1.12 (1.7.1 [0000ac01]) Lifetime: 6:06:31.601

The following information is provided:

- Column: **Output**
Designation of the output
- Column: **Cylinder**
Number of the Cylinder

- Column: **Angle**
Current firing angle of the outputs
- Column: **Min. Spark Duration**
Minimum spark duration of the outputs
- Column: **Energy Output**
Current energy release of the output
- Columns: **Misfire**
Status display for the different types of misfires (primary winding, secondary winding, open, short circuit). In case of misfire, the respective status display turns red, otherwise it is gray. With a yellow status display misfires have occurred since the last reset of the counter. If you hold the pointer over the status display, an overview of the misfire counter of the respective output is displayed for all types of misfires. A maximum up to 255 is counted per type of misfire. The counter manually resets using the menu item *Device-> Send commands -> Reset misfire counter*. When starting the engine and starting the self test the counters are automatically reset.

You have the following options:

- **Relative/Absolute**
Select via the option, whether the firing angle should be displayed absolute or relative.

8 SETTINGS VIA THE MICT

8.12.5 Runtime Data – States

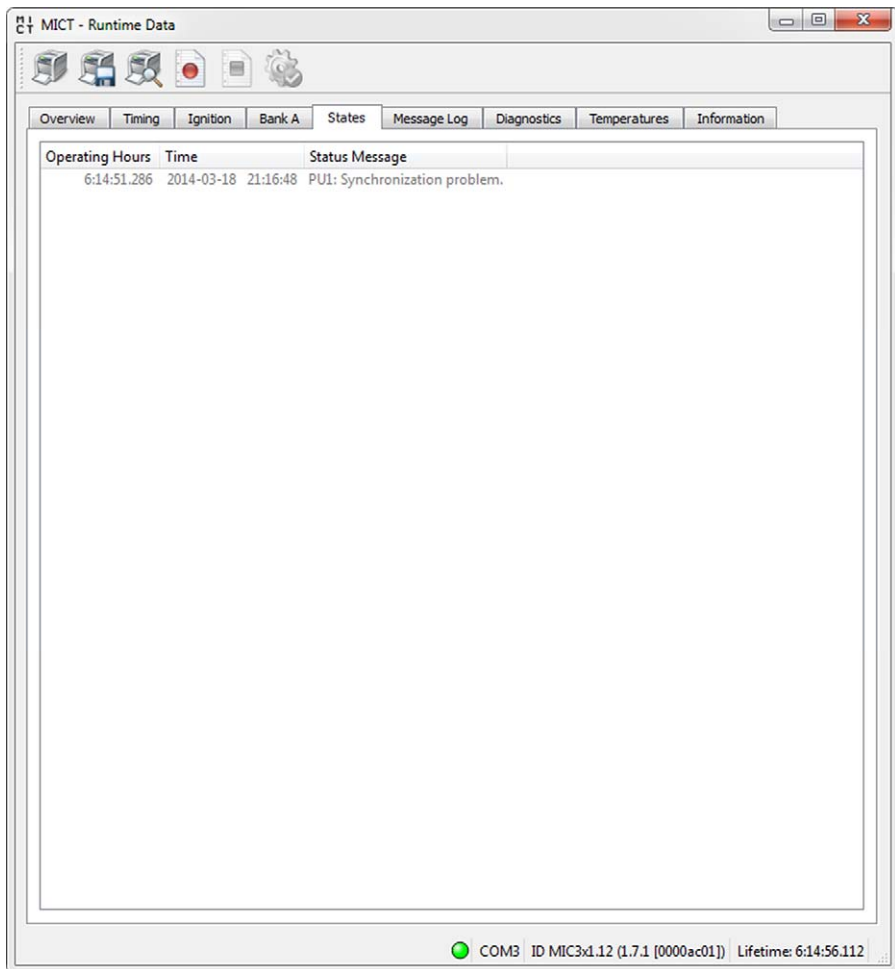

The screenshot shows the 'MICT - Runtime Data' application window. The window has a title bar with standard Windows controls (minimize, maximize, close) and a toolbar with icons for printer, folder, magnifying glass, document, and gear. Below the toolbar is a tabbed interface with tabs for Overview, Timing, Ignition, Bank A, States, Message Log, Diagnostics, Temperatures, and Information. The 'Message Log' tab is active, displaying a table with columns for Operating Hours, Time, and Status Message. A single entry is visible in the table.

Operating Hours	Time	Status Message
6:14:51.286	2014-03-18 21:16:48	PU1: Synchronization problem.

At the bottom of the window, a status bar displays a green indicator light, the text 'COM3 ID MIC3x1.12 (1.7.1 [0000ac01])', and 'Lifetime: 6:14:56.112'.

Status messages are listed in the *Status* view.

The following information is provided:

- **Operating Hours**
Operating hours counter reading at the time of message
- **Time**
Date and time of the message
- **Status Message**
Message text

Status messages are displayed in black if they are current. When a status is reset, the status message is displayed in grey for 10 seconds before it is deleted from the list.

Statusmeldung

Alarm shutdown caused by alarm *number*.

Analog current input failure (current: x mA, failure threshold: y mA, failure reset threshold: z mA).

Analog voltage input failure (voltage: x V, failure threshold: y V, failure reset threshold: z V).

Aux analog input supply voltage failure (voltage: u V, desired voltage: v V, failure threshold: x V, failure reset threshold: y V).

Aux pickup supply voltage failure (voltage: u V, desired voltage: v V, failure threshold: x V, failure reset threshold: y V).

Configuration data checksum error. Using default configuration.

Configuration invalid. Using previous configuration.

Current sensor of output bank *name* failed.

General error *number*.

Global timing x° *crankshaft* limited to range y° *crankshaft* .. z° *crankshaft*.

Incompatible coil parameters received, secondary voltage diagnostics disabled.

Output board identification failed due to a checksum error.

Output board identification failed due to incompatible hardware.

Output board identification failed due to missing data.

Output board identification failed due to unknown error *number*.

Output board identification failed due to unknown hardware.

Pickup configuration invalid.

Power failure detected on output *Anumber*.

Power output (x W) exceeded error threshold limit (y W) at a supply voltage of z V.

8 SETTINGS VIA THE MICT

Statusmeldung
Power output (x W) exceeded limit (y W) at a supply voltage of z V.
Power output (x W) exceeded permanent limit (y W) at a supply voltage of z V.
PUNumber: Faulty index.
PUNumber: Faulty Signal. Signal period (x , events counted y) is too small compared to previous signal period (z).
PUNumber: Index mark missing.
PUNumber: Missing index.
PUNumber: Missing Signal. Signal period (x , events counted y) is too great compared to previous signal period (z).
PUNumber: Missing Signal. Signal timeout occurred (events counted x).
PUNumber: No index mark found.
PUNumber: No signal.
PUNumber: Number of events (x) counted on pickup input PUNumber does not match the expected value (y).
PUNumber: Operational error.
PUNumber: Polarity detection failed.
PUNumber: Synchronization problem.
PUNumber: Wrong pickup signal polarity on pickup input PUNumber detected. Reversing polarity internally.
Self test aborted because pickup signals have been detected on pickup input PUNumber.
Speed (x RPM) exceeded overspeed limit (y RPM) at trigger signal <i>number</i> .
Temperature of device (x °C) exceeded error threshold limit (y °C).
Temperature of device (x °C) exceeded limit (y °C).
Temperature of device (x °C) exceeded permanent limit (y °C).
Temperature sensor failed.

8.12.6 Runtime Data – Message Log

Operating Hours	Time	Category	Message
5:57:50.563	2014-03-18 20:59:39	Error	Operational error caused by pickup signals. PUI = 0x00000000, PU2 = 0x00
5:58:13.943	2014-03-18 21:00:02	Info	Operational error acknowledged.
5:58:22.117	2014-03-18 21:00:10	Warning	Speed (2393 rpm) exceeded overspeed limit (1800 rpm). Previous speed wa
5:58:22.121	2014-03-18 21:00:10	Warning	Speed (2397 rpm) exceeded overspeed limit (1800 rpm). Previous speed wa
5:58:22.125	2014-03-18 21:00:10	Warning	Speed (2397 rpm) exceeded overspeed limit (1800 rpm). Previous speed wa
5:58:22.129	2014-03-18 21:00:10	Warning	Speed (2396 rpm) exceeded overspeed limit (1800 rpm). Previous speed wa
5:58:22.133	2014-03-18 21:00:10	Warning	Speed (2397 rpm) exceeded overspeed limit (1800 rpm). Previous speed wa
5:58:22.138	2014-03-18 21:00:10	Warning	Speed (2397 rpm) exceeded overspeed limit (1800 rpm). Previous speed wa
5:58:22.142	2014-03-18 21:00:10	Warning	Speed (2397 rpm) exceeded overspeed limit (1800 rpm). Previous speed wa
5:58:22.146	2014-03-18 21:00:10	Warning	Speed (2397 rpm) exceeded overspeed limit (1800 rpm). Previous speed wa
5:58:22.150	2014-03-18 21:00:10	Warning	Speed (2397 rpm) exceeded overspeed limit (1800 rpm). Previous speed wa
5:58:22.154	2014-03-18 21:00:10	Warning	Speed (2397 rpm) exceeded overspeed limit (1800 rpm). Previous speed wa
5:58:22.159	2014-03-18 21:00:10	Warning	Speed (2397 rpm) exceeded overspeed limit (1800 rpm). Previous speed wa
5:58:22.163	2014-03-18 21:00:10	Warning	Speed (2397 rpm) exceeded overspeed limit (1800 rpm). Previous speed wa
5:58:22.214	2014-03-18 21:00:10	Error	Speed (2396 rpm) exceeded overspeed limit (1800 rpm) at trigger signal 12
5:58:22.214	2014-03-18 21:00:10	Error	Operational error caused by pickup signals. PUI = 0x00000000, PU2 = 0x00
5:59:33.384	2014-03-18 21:01:21	Info	Operational error acknowledged.
6:00:02.882	2014-03-18 21:01:51	Warning	Speed (2393 rpm) exceeded overspeed limit (1800 rpm). Previous speed wa
6:00:02.886	2014-03-18 21:01:51	Warning	Speed (2397 rpm) exceeded overspeed limit (1800 rpm). Previous speed wa
6:00:02.890	2014-03-18 21:01:51	Warning	Speed (2397 rpm) exceeded overspeed limit (1800 rpm). Previous speed wa
6:00:02.895	2014-03-18 21:01:51	Warning	Speed (2397 rpm) exceeded overspeed limit (1800 rpm). Previous speed wa
6:00:02.899	2014-03-18 21:01:51	Warning	Speed (2397 rpm) exceeded overspeed limit (1800 rpm). Previous speed wa
6:00:02.903	2014-03-18 21:01:51	Warning	Speed (2397 rpm) exceeded overspeed limit (1800 rpm). Previous speed wa
6:00:02.907	2014-03-18 21:01:51	Warning	Speed (2397 rpm) exceeded overspeed limit (1800 rpm). Previous speed wa
6:00:02.911	2014-03-18 21:01:51	Warning	Speed (2397 rpm) exceeded overspeed limit (1800 rpm). Previous speed wa
6:00:02.915	2014-03-18 21:01:51	Warning	Speed (2397 rpm) exceeded overspeed limit (1800 rpm). Previous speed wa
6:00:02.920	2014-03-18 21:01:51	Warning	Speed (2397 rpm) exceeded overspeed limit (1800 rpm). Previous speed wa
6:00:02.924	2014-03-18 21:01:51	Warning	Speed (2397 rpm) exceeded overspeed limit (1800 rpm). Previous speed wa
6:00:02.928	2014-03-18 21:01:51	Warning	Speed (2397 rpm) exceeded overspeed limit (1800 rpm). Previous speed wa
6:00:02.979	2014-03-18 21:01:51	Error	Speed (2396 rpm) exceeded overspeed limit (1800 rpm) at trigger signal 12
6:00:02.979	2014-03-18 21:01:51	Error	Operational error caused by pickup signals. PUI = 0x00000000, PU2 = 0x00
6:01:31.448	2014-03-18 21:03:20	Info	Operational error acknowledged.
6:01:40.231	2014-03-18 21:03:28	Alarm	Alarm 1 "speed trip" triggered.

COM3 ID MIC3x1.12 (1.7.1 [0000ac01]) Lifetime: 6:07:31.601

Information, warnings, errors and alarms are listed in the *Message Log* view.

Information, warnings and errors are specified by the ignition controller, while alarms can be freely configured using the MICT. Refer to the section *Inputs/Outputs – Alarms* on page 82.

Errors and appropriately configured alarms shut down the engine.

8 SETTINGS VIA THE MICT

The following information is provided:

- **Operating Hours**
Operating hours counter reading at the time of message
- **Time**
Date and time of the message
- **Category**
Type of message (information, warning, error, alarm)
- **Message**
Message text

You have the following options:

- **Automatic Scrolling**
If this box is checked, the system automatically displays the last list entry until a new event occurs.
- **Acknowledge Alarms**
With this button, you can reset triggered alarms if they are no longer active. An alarm can only be acknowledged if the checkbox *Permanent - Output remains switched on until the alarm is acknowledged* in the alarm configuration is activated.



Acknowledging an operating error

While the engine is in standstill, there are the following options for acknowledging operating errors:

- Using *Error Acknowledge* in the MICT
- Restart / Reset
- Hold button *PB* on the controller longer than three seconds



Acknowledging warnings

You can acknowledge a warning by briefly pressing the pushbutton *PB* on the controller.

The following message texts can be displayed:

Information

Access control disabled.

All access control PINs reset.

CAN interface *CANnumber* entered bus off state.

CAN interface *CANnumber* left bus off state.

CAN reset requested by *GPInumber*.

CANopen on interface *CANnumber* changed state to "*name*".

Configuration changed.

Date and time set.

Device (firmware *number.number.number.number*) started at a supply voltage of *x V*.

Device reset requested by *GPInumber* failed because pickup signals have been detected.

Device switched off.

Engine operating hours set to *x h*.

Failed to change PIN of access control level "*number*".

Failed to disable access control.

Failed to enable access control.

Failed to reset all access control PINs.

J1939 on interface *CANnumber* changed state to "*name*".

One or more messages are lost due to exhausted memory pool or message queue overrun.

Operational error acknowledged.

PIN of access control level "*number*" changed.

Self test denied because no outputs are configured.

Self test started.

Self test stopped.

Spark plug operating hours set to *x h*.

Wrong pickup signal polarity on pickup input *PUnumber* detected. Reversing polarity internally.

8 SETTINGS VIA THE MICT

Warning

Configuration data checksum error. Using default configuration.

Configuration invalid. Using previous configuration.

Disable secondary diagnostic due to output *Anumber*.

Disable secondary diagnostic due to output *Bnumber*.

General warning *number*.

Incompatible coil parameters received, secondary voltage diagnostics disabled.

Invalid coil data received.

Pickup configuration invalid.

Power output (*x W*) exceeded limit (*y W*) at a supply voltage of *z V*.

Speed (*x RPM*) exceeded overspeed limit (*y RPM*). Previous speed was *z RPM*.

Temperature of device (*x °C*) exceeded limit (*y °C*)

Alarm

Alarm *number* "*description*" acknowledged.

Alarm *number* "*description*" triggered.

All alarms reset.

Errors

Alarm shutdown caused by alarm *number*.

Assertion failed (*x*).

Critical error *x* (*y*).

Current sensor failed.

Cycle signal was missing, so more trigger signals were counted than available per cycle.

Device started after supply voltage failure.

General error *number*.

General error in pickup pre-processing on pickup input *PUnumber*.

Number of trigger signals (*number*) counted does not match the configured value.

Operational error caused by pickup signals. $PU_1 = x$, $PU_2 = y$.

Output board identification failed due to a checksum error.

Errors

Output board identification failed due to incompatible hardware.

Output board identification failed due to missing data.

Output board identification failed due to unknown error *number*.

Output board identification failed due to unknown hardware.

Output board power failure detected on output *Anumber*.

Power output (*x W*) exceeded error threshold limit (*y W*) at a supply voltage of *z V*.

Power output (*x W*) exceeded permanent limit (*y W*) at a supply voltage of *z V*.

Self test aborted because pickup signals have been detected on pickup input *PUnumber*.

Speed (*x RPM*) exceeded overspeed limit (*y RPM*) at trigger signal *number*.

Temperature of controller board (*x °C*) exceeded limit (*y °C*).

Temperature of device (*x °C*) exceeded error threshold limit (*y °C*).

Temperature of device (*x °C*) exceeded permanent limit (*y °C*).

Temperature sensor of controller board failed.

Trigger period (*x*, triggers counted *y*) is not in acceptable range compared to previous trigger period (*z*).

Trigger signal missing. Current trigger period (triggers counted *x*) is out of the specified range related to the previous trigger period.

8 SETTINGS VIA THE MICT

8.12.7 Runtime Data – Diagnostics

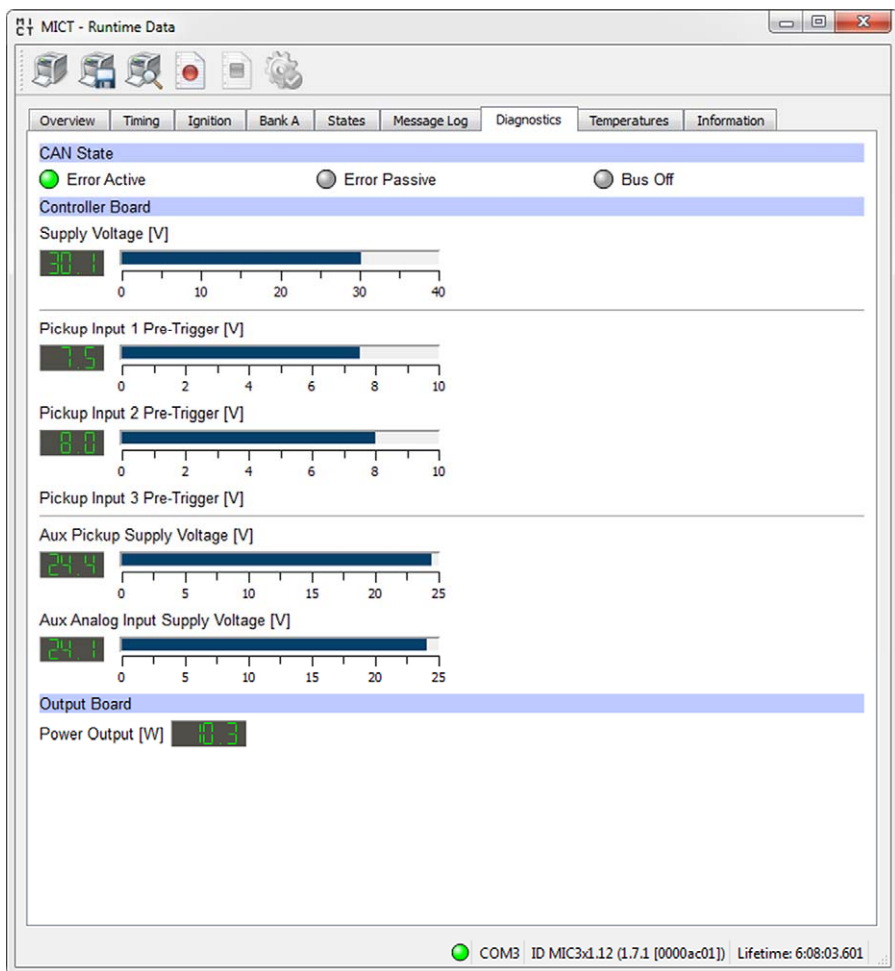

The following information is provided:

- **CAN Status**
The status display indicates the current error handling status of the device for the CAN bus communication:
 - **Error Active**
The device is in normal status of the bus communication. If an error occurs in the communication, the device sends an active Error Flag.

- **Error Passive**
After a defined number of errors in the bus communication, the device changes to the status *Passive Error*. If another error occurs, the device sends a passive Error Flag.
- **Bus Off**
The device is disconnected from the CAN bus due to error accumulations in the bus communication.
- **Controller Board**
 - **Supply voltage**
Current voltage supply of the controller board
 - **Pickup Pre-Trigger Voltage**
Current pre-trigger voltage for the pickup inputs (refer to *Engine – Pickups* on page 72). During operation the pre-trigger voltage for passive pickups is increased depending on the speed, so that the ignition controller is less prone to interferences.
 - **Aux. Pickup Supply Voltage**
Current auxiliary supply voltage of the pickups (refer to *Engine – Pickups* on page 72)
 - **Aux. Analog Input Supply Voltage**
Current auxiliary supply voltage of the analog inputs (refer to *Timing – Analog Inputs* on page 76)
- **Output Board**
 - **Power Output**
Current output of the output board

8 SETTINGS VIA THE MICT

8.12.8 Runtime Data – Temperatures

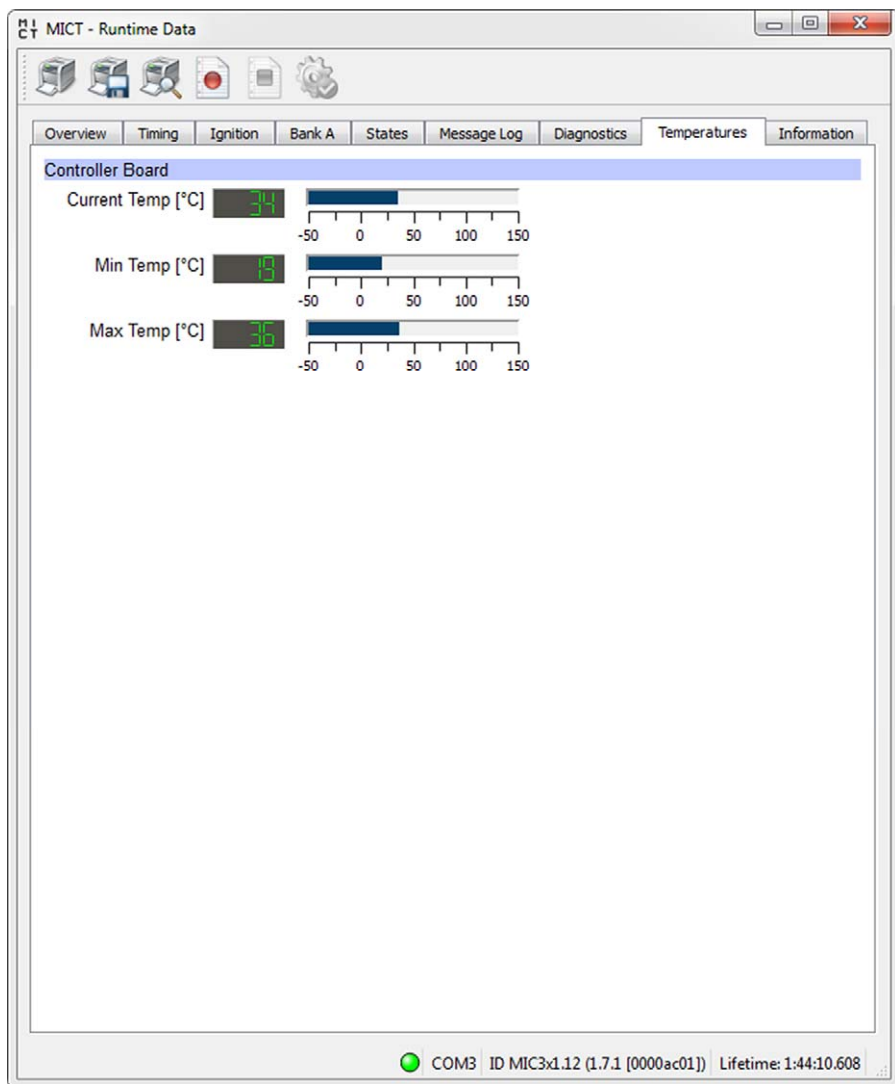

In the window you receive an overview of the temperatures of the controller board and the output board. The maximum and minimum values are reset at each new start of the ignition controller.

The following information is provided:

- **Controller Board**
 - **Current Temp.**
Current temperature of the controller board.
 - **Min. Temp.**
Minimum temperature measured on the controller board
 - **Max. Temp.**
Maximum temperature measured on the controller board

8 SETTINGS VIA THE MICT

8.12.9 Runtime Data – Information

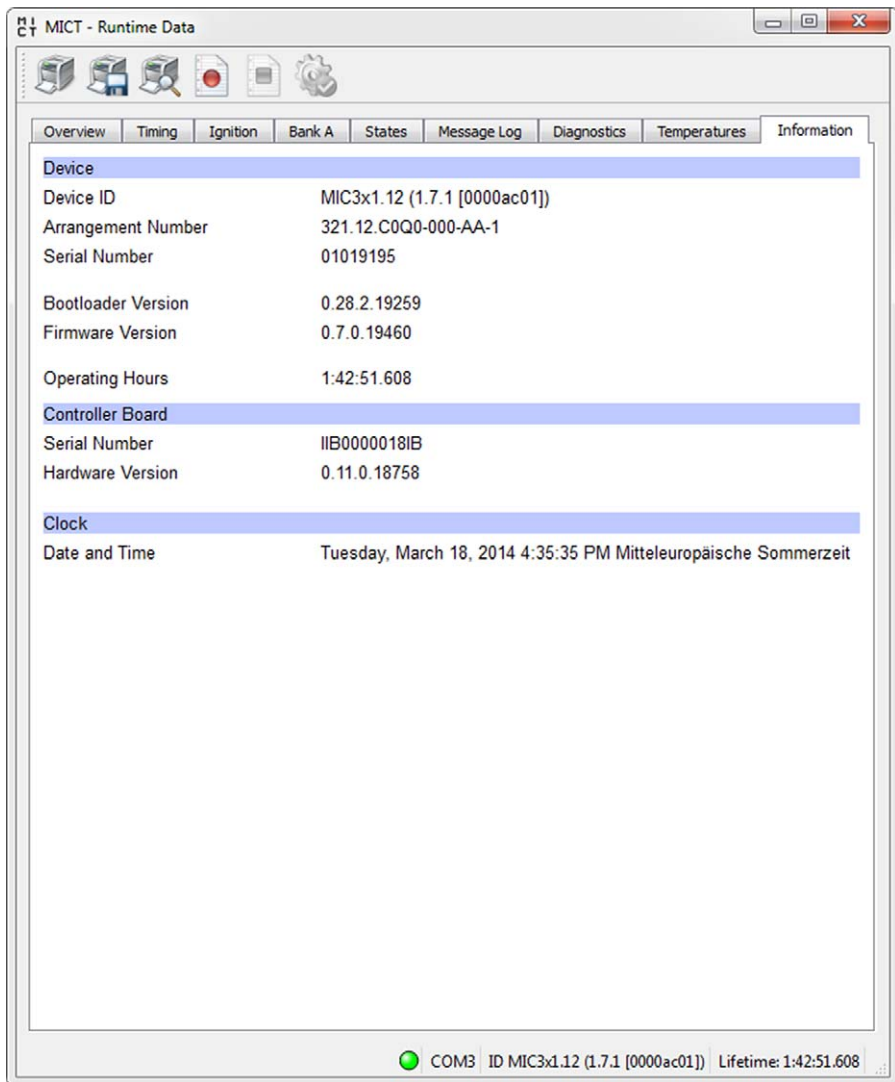

The screenshot shows the 'MICT - Runtime Data' application window. The 'Information' tab is selected, displaying the following data:

Device	
Device ID	MIC3x1.12 (1.7.1 [0000ac01])
Arrangement Number	321.12.C0Q0-000-AA-1
Serial Number	01019195
Bootloader Version	0.28.2.19259
Firmware Version	0.7.0.19460
Operating Hours	1:42:51.608
Controller Board	
Serial Number	IIB0000018IB
Hardware Version	0.11.0.18758
Clock	
Date and Time	Tuesday, March 18, 2014 4:35:35 PM Mitteleuropäische Sommerzeit

At the bottom of the window, a status bar displays: ● COM3 ID MIC3x1.12 (1.7.1 [0000ac01]) Lifetime: 1:42:51.608

In this view, you can find an overview of the device and version data. If problems arise, you can print the current runtime data and send them to the MOTORTECH Service Department by fax or as a PDF file by email. For fast support, we will then immediately have all required information.

8.13 Log



Click on the symbol to open the window *Log*. This window is only available to users with authorizations starting at the access level *Advanced Service*.

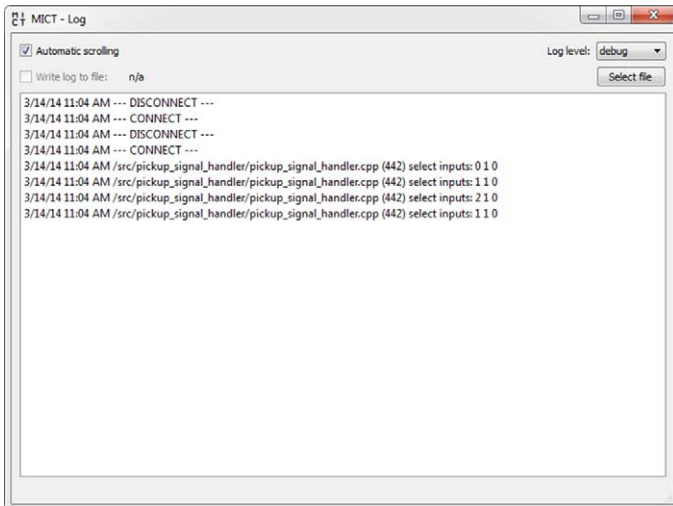

The window *Log* serves to support error diagnostics by MOTORTECH.

- **Automatic scrolling**
If the function is active, the view panel focuses on the latest message.
- **Log level**
The selection of the log level is specified by MOTORTECH if needed.
- **Write log to file**
This checkbox activates or disables, respectively, the saving of the logged data in a selected file. If the function is disabled, the logged data are merely shown on the display.
- **Select file**
With this button, you can select a file to which you want to save the logged data.

8 SETTINGS VIA THE MICT

If you are prompted to create a log file in the case of a service request, proceed as follows:

1. Open the window *Log* via the toolbar or the menu bar.
2. Select a path with the *Select file* button and enter the file name for the log file.
 - ▶ If the file does not yet exist, it is automatically created with the extension *.log*.
3. Activate the checkbox *Write log to file*.
4. Select the level specified by MOTORTECH from the *Log level* list.
5. Leave the window open.
 - ▶ The log messages are logged both in the window and in the selected file.

8.14 Runtime Adjustments



Click on the symbol to open the window *Runtime Adjustments*. This window is only available to users with authorizations starting with access level *Service*.



Runtime adjustments are implemented directly

All runtime adjustments are implemented directly without requiring the input to be confirmed and are retained even in the case of a MIC3 restart. Changes that have been saved in the device configuration are only displayed after re-uploading the device configuration in the MICT's main window.

8.14.1 Runtime Adjustments – Reset

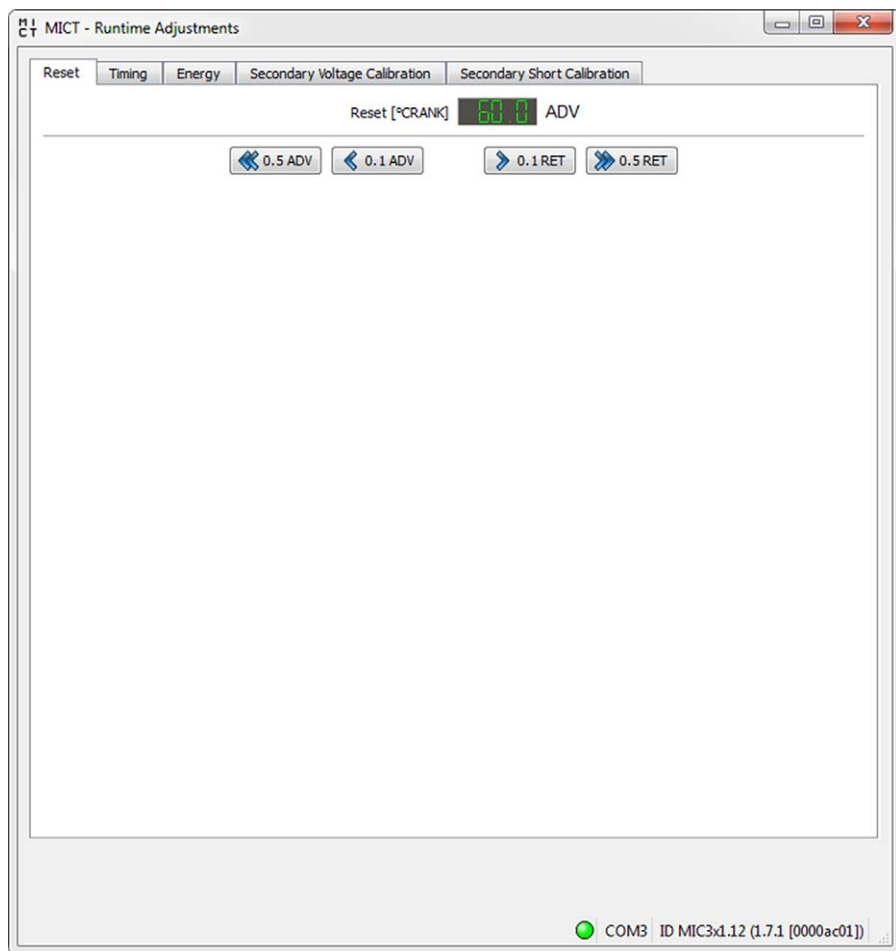

The index/reset position can be corrected by 5 °crankshaft (advanced/retarded) while the device is being operated. The correction is made with the buttons:

- 0,1 ADV/RET
in 0.1° increments to advance or retard
- 0.5 ADV/RET
in 0.5° increments to advance or retard

Changes are implemented immediately and stored in the configuration provided in the device.

8 SETTINGS VIA THE MICT

If the correction range is not sufficient, the reset/index position must be adjusted in the configuration (refer to *Engine – Pickups* on page 72).

8.14.2 Runtime Adjustments – Timing

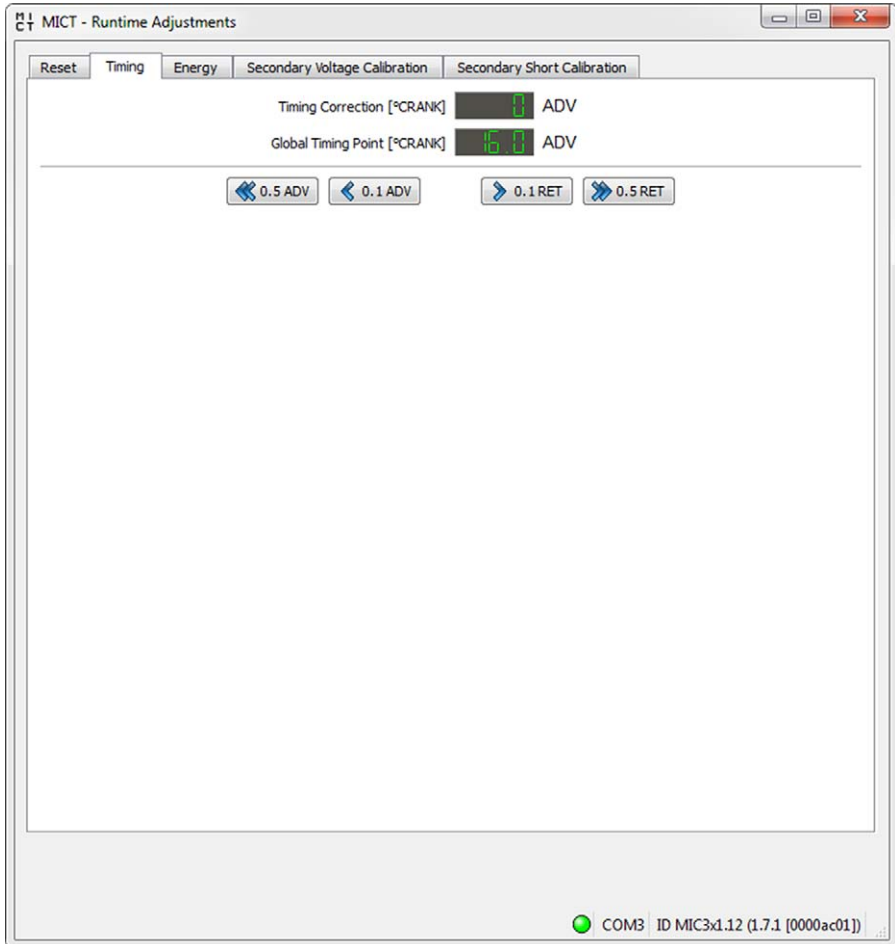

The global ignition timing position can be corrected by 50°crankshaft (advanced/retarded) while the device is being operated. The correction is made with the buttons:

- **0.1 ADV/RET**
in 0.1° increments to advance or retard

- 0.5 ADV/RET
in 0.5° increments to advance or retard

The limit for the ignition timing set in the schedule (refer to *Timing – Schedule A/B – General* on page 78) cannot be exceeded or not reached with the runtime adjustment.

The correction of the global ignition timing is immediately implemented and also remains in place if the device is restarted. NOTICE: The configuration defined in the device is not changed.

8.14.3 Runtime Adjustments – Energy

The screenshot shows the 'MICT - Runtime Adjustments' software window. It has a menu bar with 'Reset', 'Timing', 'Energy', 'Secondary Voltage Calibration', and 'Secondary Short Calibration'. The 'Energy' tab is active. The interface is divided into two sections: 'Schedule A' and 'Schedule B'. Each section contains two adjustable parameters: 'Spark Duration [µs]' and 'Spark Intensity [mA]'. Each parameter is displayed in a green digital readout (DRO) and has four control buttons: '-10', '-1', '+1', and '+10' units of the respective parameter. For Schedule A, the Spark Duration is 200 µs and Spark Intensity is 62 mA. For Schedule B, the Spark Duration is 200 µs and Spark Intensity is 60 mA. At the bottom right of the window, there is a status bar showing a green connection icon, 'COM3', and the device ID 'ID MIC3x1.12 (1.7.1 (0000ac01))'.

8 SETTINGS VIA THE MICT

The energy settings can be separately adjusted for both schedules. Changes are implemented immediately and stored in the configuration provided in the device.

Spark Duration

- +/- 1 μs
lengthen or shorten in microsecond increments
- +/- 10 μs
lengthen or shorten in 10 μs increments

Spark Intensity

- +/- 1 mA
increase and decrease in milliamperere increments
- +/- 10 mA
increase and decrease in 10 mA increments

8.14.4 Runtime Adjustments – Secondary Voltage Estimation Calibration

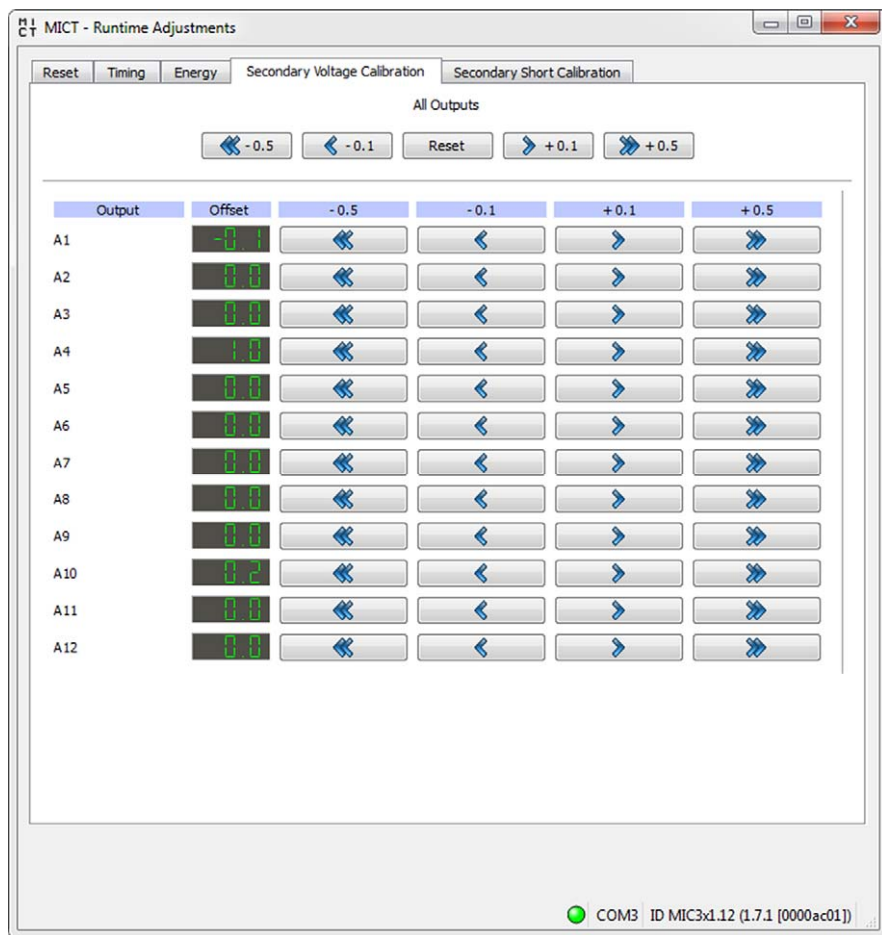

The secondary voltage estimation can be calibrated in this window when using ignition coils that support this function:

A correction value without units can be indicated for the secondary voltage estimation for every output to increase the accuracy of the secondary voltage estimation for each individual cylinder. E. g. this allows different cable lengths on the engine to be compensated.

The secondary voltage estimation should be calibrated under full load at a nominal speed. The adjustment can be made using the relevant global or individual cylinder buttons. The value range depends on the set ignition coil. 0.0 is set as the standard value for all cylinders.

8 SETTINGS VIA THE MICT

Changes are implemented immediately and stored in the configuration provided in the device.

8.14.5 Runtime Adjustments – Secondary Short Calibration

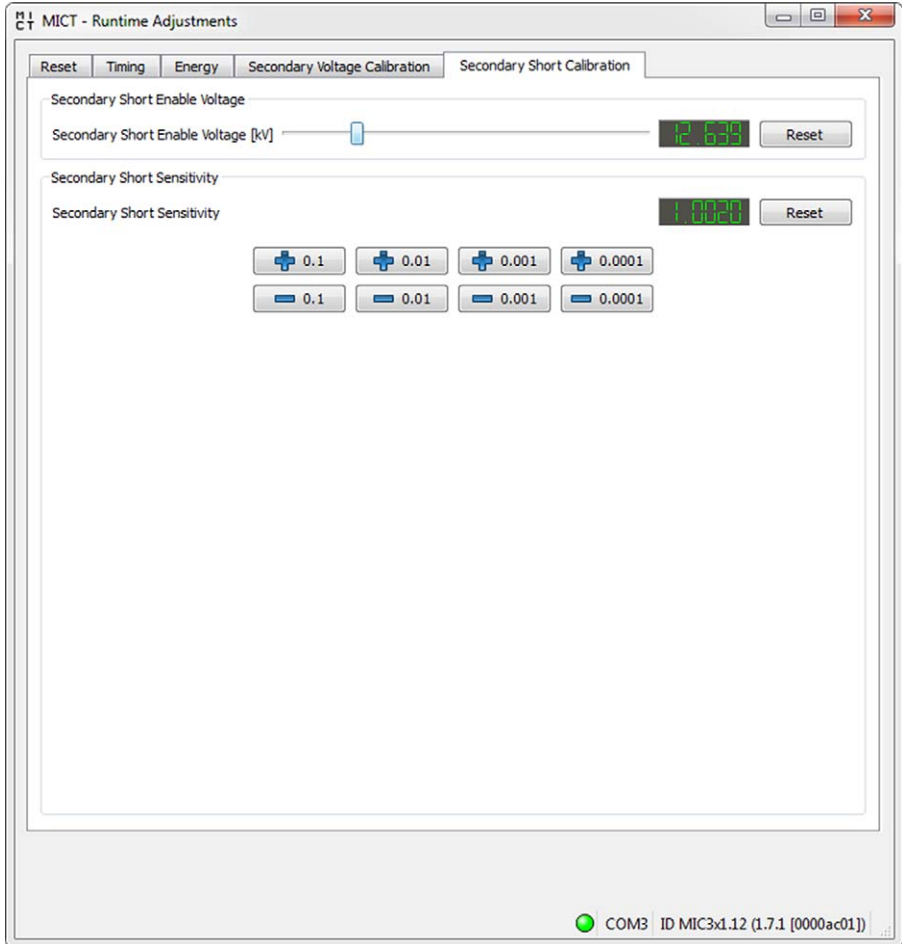

The starting voltage and sensitivity for the secondary short-circuit monitoring can be adjusted. Changes are implemented immediately and stored in the configuration provided in the device.

Secondary Short Enable Voltage [kV]:

Set the necessary average ignition voltage required to activate the secondary short-circuit monitoring:

- The secondary short-circuit monitoring is always activated at a value of 0 kV.
- The secondary short-circuit monitoring is always deactivated at a value of 65.535 kV.

Secondary Short Sensitivity

The permitted value range depends on the set ignition coil.

E. g. set the sensitivity of the short-circuit monitoring as follows:

- The sensitivity is high at a value of 0.98.
- The sensitivity is low at a value of 1.02.



Adjust the sensitivity of the secondary short detection

If a short-circuit is misdiagnosed at a sensitivity of 1.00, the sensitivity must be set to 1.02.

If a short-circuit is not detected at a sensitivity of 1.00, the sensitivity must be set to 0.98.

8.15 Cylinder Individual Offsets



Click on the symbol to open the window *Cylinder Individual Offsets*. This window is only available to users with authorizations starting with access level *Service*.

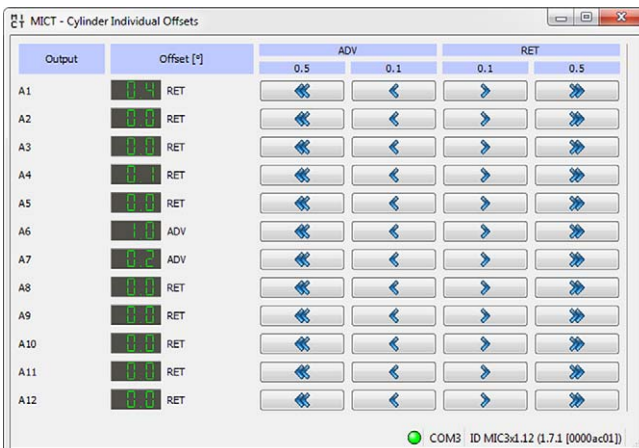

8 SETTINGS VIA THE MICT

The cylinder individual offset can be applied to the position of the timing point while the controller is being operated. Offset via keys:

- **0.1 ADV/RET**
in 0.1° increments to advance or retard
- **0.5 ADV/RET**
in 0.5° increments to advance or retard

The adjustment option of this function is limited by the specified settings in the configuration. Refer to the section *Timing – Schedule A/B – General* on page 78.



Immediate execution of the changes

Please note that changes made to the timing point are executed immediately at the next firing of the corresponding cylinder. The maximum performed change per cycle is however limited by the corresponding setting in the configuration. For this read *Timing – Miscellaneous* on page 81.



Save changes automatically

Please remember that changes to the ignition timing are saved automatically.

8.16 Schedule Curve



Click on the symbol to open the window *Schedule*.

8.16.1 Schedule Curve – Simulation

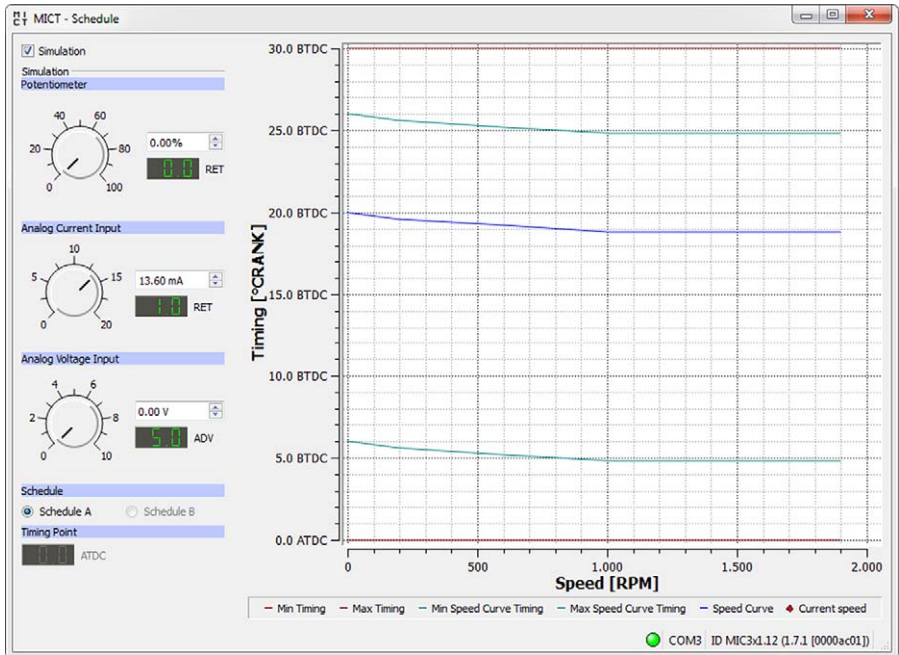

The schedule curve visualizes the configurations of the schedules and simulates the influence of the inputs via the speed range. With the optional input fields, you can switch between schedule A and B. Changes made by turning the control buttons or entering the desired values are displayed simultaneously.

- **Simulation**
The simulation is activated or disabled using the checkbox.
- **Potentiometer**
Simulation of the potentiometer
 - Control button for adjustments between 0 % and 100 %
 - Field for manual input of the desired value in %
 - Displays the value in °crankshaft by which the timing is offset
- **Analog Current Input**
Simulation of the analog current input
 - Control button for adjustments between the configured values (e. g. 0 mA and 20 mA)
 - Field for manual input of the desired value in mA

8 SETTINGS VIA THE MICT

- Displays the value in °crankshaft by which the timing is offset
- **Analog Voltage Input**
Simulation of the analog voltage input
 - Control button for adjustments between the configured values (e. g. 0 V and 10 V)
 - Field for manual input of the desired value in V
 - Displays the value in °crankshaft by which the timing is offset
- **Schedule A/B**
Select between schedule A and B.
- **Timing Point**
Displays the global ignition timing as it changes during the simulation

While connected to the device, the ignition timing is simulated depending on the actual engine speed and marked as  in the diagram.

8.16.2 Schedule Curve – Runtime Values

If the *Simulation* box is unchecked, the *Schedule curve* window switches to the current runtime data.

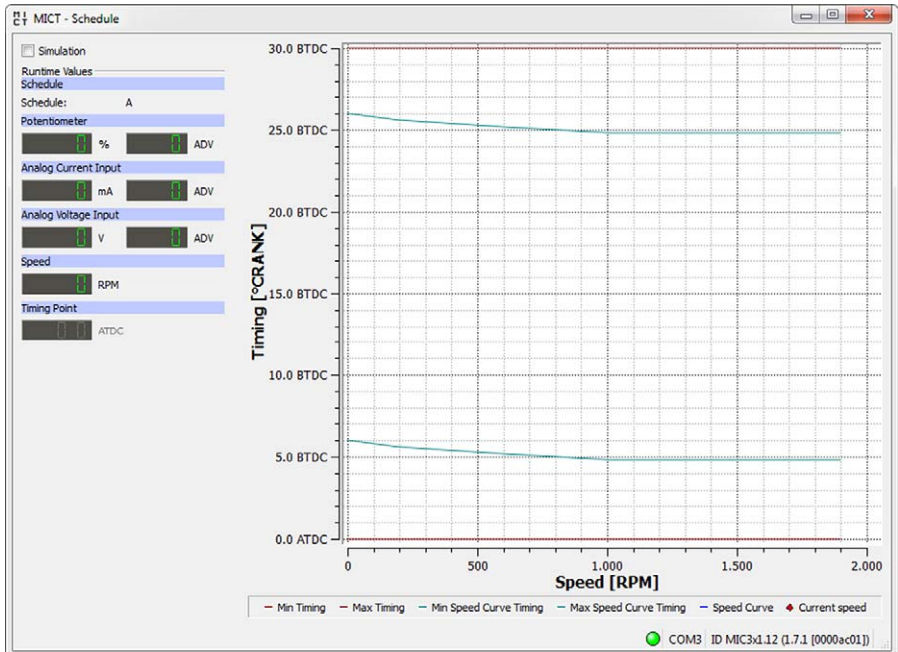

The following information is provided:





- **Schedule**
Displays the currently selected schedule.
- **Left column: Potentiometer, Analog Current Input, Analog Voltage Input**
Displays the new calculated adjustment values for the potentiometer, current and voltage input.
- **Right column: Potentiometer, Analog Current Input, Analog Voltage Input**
Displays the values supplied by the ignition controller for the potentiometer, current and voltage input.
- **Speed**
Displays the current speed
- **Timing Point**
Displays the current global ignition timing

8.17 Coils

The MICT has a database with technical information on MOTORTECH ignition coils. Open the database as follows:

Tools -> Coils

You have the option of storing and printing information on the ignition coils present in the database. For this purpose, the following functions are at your disposal in the toolbar in the *Coils* window:

Symbol	Function
	Stores the information on the selected ignition coils in a format that is appropriate for configuring the MIC ₃ via fieldbus.
	Prints the selected coil data set.
	Prints the selected coil data set as a PDF file.
	Opens the print preview.

Coils

- **Device**
Select an ignition controller.
- **Coil**
Select an ignition coil.

8 SETTINGS VIA THE MICT



Select the correct ignition controller

The ignition coil data depends on the ignition controller used. Always select the ignition controller for which you are using the coils in order to obtain the correct data.

8.17.1 General

Parameter	Min.	Max.
Max. Breakdown Voltage [kV]	19	40
Spark Intensity [mA]	32	190
Secondary Voltage Estimation Calibration	-5	5
Secondary Short Sensitivity	0.98	1.02

Details

The following information is provided:

- **Name**
Coil name
- **Coil Type ID**
Used to clearly identify the ignition coil
- **Data Version**
Shows the data version of the selected ignition coil in the database. The data version of the ignition coil configured in the ignition controller is displayed in the runtime data in the *Ignition* view (refer to *Runtime Data – Ignition* on page 94). The Automatic Online Update should be activated to ensure that the coil database always has the latest data sets. Additional information on the online update is provided in *Online Update Settings* on page 55.

- Illustration of the ignition coil
- Information on the conditions under which a secondary diagnosis is possible using the displayed ignition coil.

Coil Parameters

The following information is provided:

- **Max. Breakdown Voltage [kV]**
Displays the permitted value range for the maximum breakdown voltage in kV. The maximum breakdown voltage is configured in the *Timing – Schedule A/B – Energy* view (refer to *Timing – Schedule A/B – Energy* on page 80).
- **Spark Intensity [mA]**
Displays the permitted value range for the spark intensity in mA. The spark intensity is configured in the *Timing – Schedule A/B – Energy* view (refer to *Timing – Schedule A/B – Energy* on page 80).
- **Secondary Voltage Estimation Calibration**
Displays the permitted value range for the secondary voltage estimation calibration. The secondary voltage estimation calibration takes place in the *Engine – Ignition Coils* view (refer to *Engine – Ignition Coils* on page 70) and in the runtime adjustments (refer to *Runtime adjustments – Secondary Voltage Estimation Calibration* on page 117).
- **Secondary Short Sensitivity**
Displays the permitted value range for the calibration of the secondary short sensitivity. The calibration of the secondary short sensitivity takes place in the *Engine – Ignition Coils* view (refer to *Engine – Ignition Coils* on page 70) and in the runtime adjustments (refer to *Runtime adjustments – Secondary Short Calibration* on page 118).

8 SETTINGS VIA THE MICT

8.17.2 Minimum Energy Limitation Curve

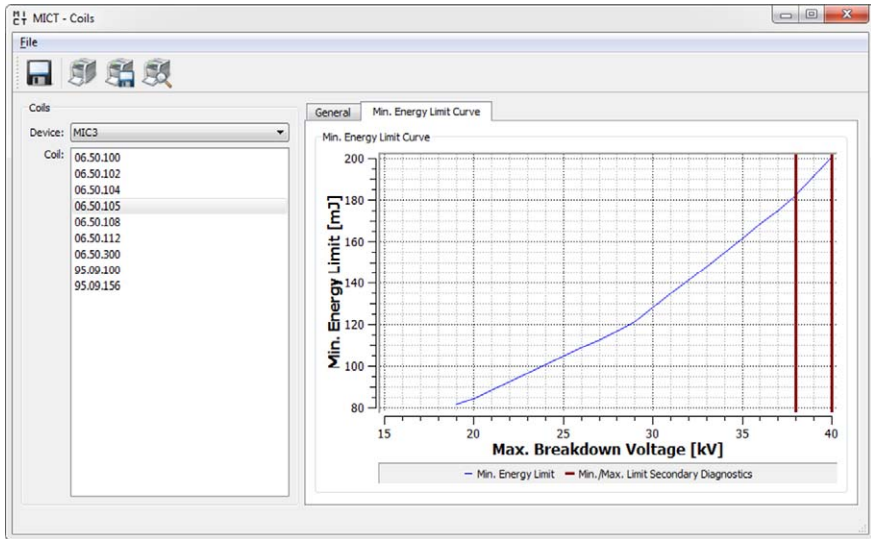

Min. Energy Limit Curve

The curve provides information on the energy in mJ necessary to achieve a certain maximum breakdown voltage in kV. The two vertical bars show the breakdown voltage area, in kV, in which a secondary diagnosis is possible. The corresponding energy settings can be found in the *Timing – Schedule A/B – Energy* view (refer to *Timing – Schedule A/B – Energy* on page 80).

When printing the coil data set, the curve values are also provided as a list.

9 OPERATION

9.1 Start-up

Before you start up the MIC3 ignition controller, take note of the following:

- Were the correct engine, ignition sequence, and output configuration selected? If you are unsure, contact MOTORTECH or the corresponding engine manufacturer.
- Ensure that the firing order of the engine and/or the wiring of the output cable harness are carried out correctly.
- Is the wiring of all pickups compliant with the drawings given in this operating manual?
- Are the distances of the pickups to trigger discs, projectiles, etc. correctly set (refer to *Determine the Installation Location of the Pickup* on page 22)?
- Ensure that the data were transferred flawlessly to the controller.
- Check whether the start/stop input is set to *Firing Active*, or whether it works according to the control requirements of the master control.
- Check whether the input contact for parameter settings A/B (*Schedule A/B*) functions and ensure that the correct schedule (A or B) was selected for start-up.
- Ensure that no gas is present in the inlet and exhaust systems before you start the engine.
- Ensure that the gas valve is closed.
- Perform the normal engine start-up process while the gas valve is closed (start only).
- Connect a stroboscope to the first firing cylinder (cylinder #1) and check whether the timing point set on the ignition controller coincides with the actual timing point on the crankshaft. If the ignition timing point does not coincide exactly, change it (refer to *Runtime Data* on page 89) until the optimum setting is reached. If the ignition does not fire, read the instructions in section *Troubleshooting and Eliminating Errors* on page 132.
- Check all other cylinders for correct ignition. If they are not correct, stop the engine, and recheck wiring and ignition sequence for correctness.
- Stop the starting process. If no problems occur, start the engine in accordance with the specifications of the engine manufacturer.

9.2 Shut-Down

The ignition controller is shut down by disconnecting it from the power supply.

9.3 Firmware Update

Using the MOTORTECH Flash Tool, you can perform a firmware update for the ignition controller. The provided CD-ROM comprises this program.

9 OPERATION

Install MOTORTECH Flash Tool



This is how to install the MOTORTECH Flash Tool:

1. Start the installation.
 - Insert the CD-ROM into the CD/DVD drive of your PC. If the Autostart function is enabled for the drive, cancel the installation program for the MOTORTECH Integrated Configuration Tool if necessary.
 - Copy the *MOTORTECHFlashTool-x.x.x.zip* file (e. g. *MOTORTECHFlashTool-o.8.3.zip*) to your PC.
 - Unzip the file.
 - Start the installation process by running the unzipped *setup.exe* file.
2. Install the program.

Follow the installation process instructions. Please note that the license agreement terms must be accepted before using the MOTORTECH Flash Tool. If the terms are not accepted, the installation cannot continue.
3. If not already completed, install the USB driver by running the *CDMxxxx_Setup.exe* file (e. g. *CDM2o824_Setup.exe*) on the CD-ROM.
 - ▶ The MOTORTECH Flash Tool is now set up. You can connect your PC to the ignition controller via the USB interface.

Menu Bar and Toolbar

After launching the MOTORTECH Flash Tool, the following functions are available to you via the icons on the toolbar and the entries in the menu bar:

Symbol	Menu	Function
	<i>File -> Open</i>	Opens a firmware file.
	<i>File -> Quit</i>	Exits the program.
	<i>View -> Extended File Information View</i>	Fades in / out additional information of the firmware file.
	<i>View -> Extended Connection Settings</i>	Fades in / out additional information and settings of the connection to the device.
	<i>View -> Reload File</i>	Reloads the file information of the selected firmware file.
	<i>Device -> Search Devices</i>	Restarts the search for connected devices.

Symbol	Menu	Function
	<i>Device -> Program Device</i>	Starts the update process or downgrade process.
	<i>Settings -> Language</i>	Opens the window <i>Select Language</i> in which you can change the interface language of the program.
	<i>Help -> Help</i>	Opens the online help function.
	<i>Help -> About MOTORTECH Flash Tool</i>	Opens detailed information on the program.

Start Firmware Update



Access control for firmware update

If you have activated the access control for the ignition controller, you need the PIN for the level *Master* for the firmware update.



Backup the existing configuration

Your device's configuration may be lost if the firmware update is not performed properly. Always backup the existing configuration via the MICT prior to performing an update. For further information please refer to *Working with Configurations* on page 61.

To start the firmware update, proceed as follows:

1. If an MICT is connected with the ignition controller, please disconnect this connection.
2. Start the MOTORTECH Flash Tool via *Start -> Programs -> MOTORTECH -> MOTORTECH Flash Tool -> x.x.x (e. g. o.8.3) -> MOTORTECH Flash Tool*.
 - ▶ The MOTORTECH Flash Tool will now start.
 - ▶ The software automatically checks all ports for connected devices.
3. Check whether your device has been correctly identified in *Status* under *Device*.
 - ▶ If the MOTORTECH Flash Tool does not recognize a device that is connected to your PC via the USB interface, you can usually still carry out a firmware update. To do so, observe the instructions in the information windows of the MOTORTECH Flash Tool for the following steps.

9 OPERATION

4. Select the desired update file in *File* using the *Select* button.
5. By reading the displayed file information, ensure that the update file is correct for your device.
6. Start the update process using the *Flash* button or using the menu or toolbar.
 - ▶ The ignition controller is restarted automatically.
 - ▶ Now, a window opens informing you about the firmware version currently used on your ignition controller and also about the relevant update version.
7. Please confirm with *Yes* to proceed with the update process.
 - ▶ Now the update will start.
 - ▶ If the firmware update was successful, you will see a relevant message.
8. After a successful firmware update, check all configuration data.



Downgrade process

The process for a downgrade is largely the same as the update process. You will only be informed that a new firmware has been installed on the device.



Help with connection problems

If a correctly connected device is not found during the automatic search, this can, for example, be because too many communication interfaces are assigned and must be checked. In this case an interface from the drop-down list *Port* in area *connection* can be selected and thus specified.

If the desired port is not yet displayed in the list or if the problem should continue, an adjustment of the time-outs for the connection helps. The time-out settings are displayed in the main view by the following entry in the menu bar: *View -> Extended connection settings*.

Enter the following settings:

- **Update Request Timeout**
Adjustment range: 1000 ms to 10000 ms, default value: 3000 ms. An extension of the time-out can be an advantage, especially with connection problems that occur because the computer has many assigned ports.
- **Start Timeout**
Adjustment range: 1000 ms to 10000 ms, default value: 3000 ms. A time-out change can be an advantage, especially with connection problems that occur because the communication between the computer and the device has been interrupted.

10 DISTURBANCES

10.1 Possible Faults

The MIC₃ ignition controllers include several safety functions that can shut down the engine in case of fault:

- Overspeed protection
- External shut-down contact (Start/Stop)
- Misfire detection (primary)
- Internal failure of the high voltage supply
- Output Error Detection
- Shut down in the case of a faulty pickup or faulty pickup signals.
- Alarms
- Faulty voltage supply
- External EMI signals

10.2 Causes for Faults

10.2.1 Overspeed

The engine speed has exceeded the set overspeed value.

Potential causes:

- Speed controller does not function properly
- Fuel supply to engine is not optimal.
- Faulty pickup signal

10.2.2 Output Error Detection

An internal failure of the high voltage supply or a defective output switch occurs.

Potential causes:

- Hardware defect on the MIC₃
- Defect in the wiring (short circuit or open circuit)

10.2.3 Misfire Detection (Primary)

Misfiring due to an open circuit on the primary side was detected and displayed in the runtime data.

Potential causes:

- Defect in the output wiring
- Ignition coil defective

10 DISTURBANCES

10.2.4 Pickup Input Errors

Faulty input signals from the pickups are detected.

Potential causes:

- Number of teeth on the flywheel does not coincide with the set number.
- Interference in the wiring of the pickup
- Wiring of the pickup incorrect
- Distance of the pickup incorrect
- Dirt on the pickup

10.2.5 Acknowledging Faults

While the engine is shut down, you have the following options for acknowledging operating errors:

- Using *Error Acknowledge* in the MICT
- Acknowledgement of the error via CAN bus or RS485.
- By disconnecting the supply voltage

10.3 Troubleshooting and Eliminating Errors

10.3.1 Running a Self Test

You can run the self test via the MICT to check the order of the wiring and the connection between the ignition controller outputs and the spark plugs. For this read section *Self Test* on page 56.



Operational safety!

If you carry out a self-test, it is essential for the gas supply to be switched off and no more residual gas is left in the combustion chamber. Non-compliance can result in damage to equipment or injury to persons.

10.3.2 Causes of Typical Errors

The table defines possible causes of errors that are dealt with in the MICT status and message texts.

Issue	Description	Causes
Trigger number	Number of events per cycle counted does not correspond with set value.	<ul style="list-style-type: none"> – Set value is wrong. – Ring gear is defective. – Trigger disk runs out-of-center – Faults on reset, index camshaft/crankshaft – Reset is polarized incorrectly. – Pickup is dirty. – Pickup wiring is damaged. – Defective connection to the pickup
Trigger signal missing	Number of counted events is smaller than expected number.	<ul style="list-style-type: none"> – Reset is polarized incorrectly. – Contaminations have occurred on the trigger disk during operation. – Trigger disk / ring gear was damaged during operation. – Pickup wiring is defective.
Cycle signal missing	Cycle signal was not detected in time. More events were counted than is expected per cycle.	<ul style="list-style-type: none"> – Reset is polarized incorrectly. – Faults on reset, index camshaft/crankshaft occurred. – Wiring to camshaft/crankshaft pickup is defective. – Trigger signal was jammed.
Reset number	Number of reset events are outside expected range.	<p>NOTICE Only for 4-stroke engines: Interference coupling on reset signal.</p>

10 DISTURBANCES

Issue	Description	Causes
Trigger period	Current event period is outside the valid range with reference to the previous event period.	<ul style="list-style-type: none"> – Interference coupling on trigger signal – The wiring to the trigger pickup is defective. – The trigger pickup is dirty. – Trigger disk / ring gear was damaged during operation.
Pickup preprocessing	Pickup preprocessing causing errors.	NOTICE N+1 / N-1 trigger discs
Overspeed	Overspeed	<ul style="list-style-type: none"> – Overspeed – Interference coupling on trigger signal
Shutdown due to alarm	The ignition is shut down due to an alarm.	– The limit set for an alarm resulting in engine shut-down was exceeded or not reached.
Temperature	The max. permissible device temperature was exceeded.	– Ambient temperature too high
Pickup signals in the self test	The self test was aborted because pickup signals were detected.	<ul style="list-style-type: none"> – Interference coupling on pickup signal. – Engine was started.
Recognition of output board failed	Characteristic data of the output board could not be read, they are defective or do not match the device.	NOTICE Send the device to MOTORTECH.
Interruption of power supply to the output board	The HV power supply reported an error.	NOTICE Send the device to MOTORTECH.
Current sensor error	Errors occurred during current measurement.	– Sensor defective
Limit for temperature exceeded	The error is triggered if the device temperature exceeds a specific value.	– Ambient temperature too high
Limit for output exceeded	The error is triggered if the output exceeds a specific value.	– The supply voltage is not sufficient for the entered energy settings.

A list with status messages is provided in *Runtime Data – States* on page 98.

Lists with information, alarm, warning and error messages are provided in *Runtime Data – Message Log* on page 101.

10.3.3 Customer Service Information

You can reach our customer service during business hours at the following phone and fax number, or by e-mail:

Phone: +49 5141 93 99 0
Fax: +49 5141 93 99 99
Email: service@motortech.de

10.3.4 Returning Equipment for Repair / Inspection

To return the device for repair and inspection, obtain a return form and return number from MOTORTECH.

Fill out the return form completely. The completely filled out return form guarantees fast, uncomplicated processing of your repair order.

Send the device and the return form to one of the two addresses below or to the nearest MOTORTECH representative:

MOTORTECH GmbH

Hogrevestr. 21-23
29223 Celle

Germany

Phone: +49 5141 93 99 0
Fax: +49 5141 93 99 98

www.motortech.de
motortech@motortech.de

MOTORTECH Americas, LLC

1400 Dealers Avenue, Suite A
New Orleans, LA 70123

USA

Phone: +1 504 355 4212
Fax: +1 504 355 4217

www.motortechamericas.com
info@motortechamericas.com

10.3.5 Instructions for Packaging the Equipment

For return shipment, equipment should be packaged as follows:

- Use packaging material that does not damage the equipment surfaces.
- Wrap the equipment with sturdy materials and stabilize it inside the packaging.
- Use sturdy adhesive film to seal the packaging.

11 MAINTENANCE

11.1 Maintenance Instructions

Please follow the following maintenance instructions:

- Do not use caustic liquids or steam cleaners for cleaning the device.
- Clean the passive pickups at regular intervals.
- Check the ignition wires at regular intervals.
- Replace the pickups at regular intervals if operating at elevated temperatures (> 90° C / > 194° F).
- Regularly inspect all wires of the ignition system for damage and replace the wires as needed.
- Check all plug-in connections for proper condition.
- Service the spark plugs as per the instructions of the spark plug and engine manufacturers.

11.2 Spare Parts and Accessories

For spare parts and accessories for MIC3 ignition systems, please refer to our current product guide, which is available to you for download on the Internet at www.motortech.de.

12 INDEX

A

Abbreviation	8
Access Control	
Activate.....	60
Device.....	59
Overview	47
Advanced Service	
Access Level.....	50
Alarm	
Function.....	44
Setting.....	82
Arrangement Number.....	14
Article number.....	14
ASO	
Example.....	45
Function.....	45
Setting.....	84
Wiring	29
Auxiliary Synchronization Output	
Example.....	45
Function.....	45
Setting.....	84
Wiring.....	29

B

Base timing	
Setting.....	78

C

CAN Bus	
Interface	17
Setting.....	86
Status	106
Wiring.....	32
Cleaning	136
Coil Type	
Set.....	64
Coils	123
Configuration	
Download.....	61
Open.....	61
Upload.....	61
Current input	
Current value.....	114
Function.....	41
Setting.....	76, 78
Customer	
Access Level.....	50

Cylinder Name	67
---------------------	----

D

Declaration of Conformity.....	14
Device	
Application Range.....	13
Dimension.....	19
Disposal.....	12
Electrical data.....	15
Function	13
Installation	21
Mechanical data	14
Return.....	135
Start-Up	127
Switching off	127
Downgrade	
Process Sequence.....	127

E

Electrostatics	11
Energy	
Overview	47
Setting	80, 115
Engine	
Define	68
Selection.....	64
Setting.....	64
Engine database.....	64, 68
Errors	
Acknowledge	52, 132
Logging.....	111
Overspeed.....	131
Overview	133
Pickup.....	132

F

Firmware	
Downgrade.....	127
Update	127

G

General purpose output	
Function	45
Wiring	29
Go/NoGo output	
Function.....	39
Wiring	29
GPO	
Function	45
Wiring	29

H

Hall Effect Sensor	
Supply Voltage	72

12 INDEX

I

Ignition coils	
Setting	70
Wiring	34
Ignition controller	
Application Range	13
Dimension	19
Disposal	12
Electrical data	15
Function	13
Installation	21
Mechanical data	14
Return	135
Start-Up	127
Switching off	127
Ignition Energy	
Overview	47
Ignition Timing	
Base	90, 93
Cylinder Individual Offset	119
Global	90, 93
Limits	78
Overview	93
Setting	114
Ignition timing reduction	
Maximum	81
Overview	40
Index	
Setting	72
Information	
To device	110
Input	
Electrical data	15
Installation	21, 22
L	
Log File	
Create	111
M	
Maintenance	
Pickup	136
Spark plugs	136
Menu	
Access Level	50
Design	51
Installation	49
Menu Overview	52
Operation	51
Symbol Overview	52
System requirements	49
Update	55

MIC3

Application Range	13
Dimension	19
Disposal	12
Electrical data	15
Function	13
Installation	21
Mechanical data	14
Return	135
Start-Up	127
Switching off	127
Misfire Rate	
Causes	131
Misfiring	
Overview	94, 96
MOTORTECH Integrated Configuration Tool	
Access Level	50
Design	51
Installation	49
Menu Overview	52
Operation	51
Symbol Overview	52
System requirements	49
Update	55
Multiple Ignition	
Activate	64

N

Nominal Speed	
Setting	72

O

Operating Data	
Overview	90
Print	89
Operating Hours	
Engine	90
Set	52
Spark plug	90
Operating Hours Counter	
Reset	136
Output	
Electrical data	15
Multiple Ignition	68
Overspeed	
Exceeded	131
Setting	72

P

Parameter Settings (Schedule)	
Function	44
Representation	122
Setting	78, 80
Simulation	121
Pickup	
Calculate frequency	15
Check	39
Maintenance	136
Record	57
Setting	72
Supply Voltage	72
Wiring	26
Pickup Input	
Setting	72
Pickup Sensitivity	
Function	39
PIN	
Change	60
Reset	61
Potentiometer	
Current value	93
PowerView3	
Wiring	31
Pre-trigger voltage	
Display Unit	106
Setting	72
Printing	
Operating Data	89
R	
Read Only	
Access Level	50
Regulations	
Overview	14
Required current	15
Reset	
Setting	113
RS485 interface	
Wiring	33
S	
Safety Device	
Wiring	28
Safety Function	
Overview	131
Safety instructions	10
Scope of Supply	21
Secondary Voltage	
Secondary short-circuit monitoring	118
Secondary voltage estimation	117

Security Speed	
Setting	72
Self Test	56, 132
Serial number	
Device	14
Service	
Access Level	50
Service Contact	
Setting	88
Software	
Access Level	50
Design	51
Installation	49
Menu Overview	52
Operation	51
Symbol Overview	52
System requirements	49
Update	55
Spark Duration	
Setting	80
Sparkplug Hours	
Set	52
Speed	
Current value	90
Max. value	90
Speed Curve	
Current value	93
Function	43
Setting	78
Starter Speed	
Setting	72
Start-Up	127
Supply voltage	
Analog inputs	76
Pickup	72
Wiring	25
Switching off	127
System State	
Overview	90
T	
Temperature	
Board	108
Timing Correction	
Current value	93
Function	43
Timing Set-Up	
Wiring	28
U	
Update	
Process Sequence	127

12 INDEX

USB	
Connections.....	17
V	
Voltage input	
Current value	93
Function	41
Setting	76, 78
W	
Wiring	
Auxiliary Synchronization Output	29
CAN Bus.....	32
Direct	36, 64
General purpose output.....	29
Go/NoGo Output	29
Pickup	26
PowerView3	31
Safety Device	28
Supply voltage	25
Timing Set-Up	28

WE UPGRADE GAS ENGINES

Original MOTORTECH Accessories for Stationary Gas Engines

As a supplier, MOTORTECH develops, produces and distributes accessories as well as spare and wearing parts for nearly all kinds of stationary gas engines worldwide: Ignition control and monitoring, industrial spark plugs and high tension leads, wiring systems and gas regulation – from detonation to speed control and complete gas engine management. On-site support and special training courses complete our service.



MOTORTECH GmbH

Hogrevestr. 21-23
29223 Celle
Phone: +49 5141 93 99 0
Fax: +49 5141 93 99 99
www.motortech.de
motortech@motortech.de

MOTORTECH Americas, LLC

1400 Dealers Avenue, Suite A
New Orleans, LA 70123
Phone: +1 504 355 4212
Fax: +1 504 355 4217
www.motortechamericas.com
info@motortechamericas.com